

Angle - Equal Legs

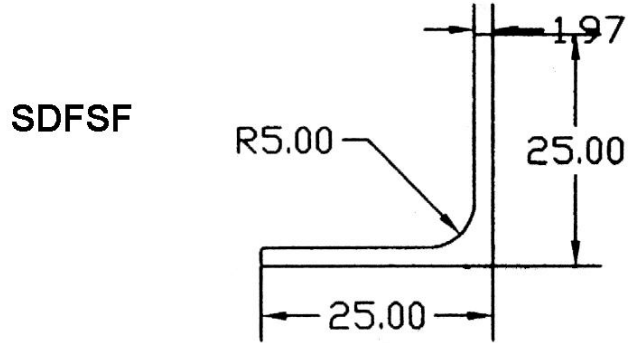

SECTION NO.	T	WEIGHT-RANGE KG/12'
401	1.50	0.750 - 0.800
402	1.97	0.950 - 1.00KG

Angle - Unequal Legs

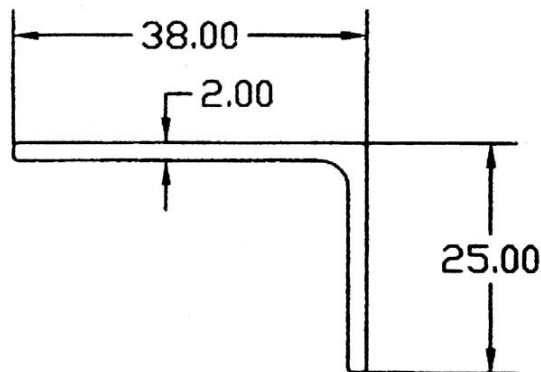

SECTION NO.	T	WEIGHT-RANGE KG/12'
501	1.30	0.800 - 0.900
502	2.00	1.200 - 1.350
503	2.07	1.600 - 2.000
504	2.8	1.650 - 2.250





# An ISO 9001 : 2008 Certified Company

## Angle - Fluted Angle

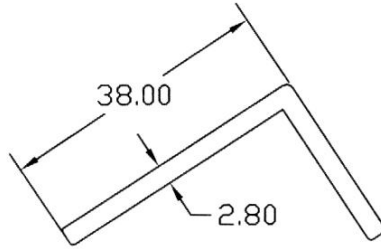

SECTION NO.	T	WEIGHT-RANGE KG/12'
505	2.80	1.650

## Angle - Unequal Legs

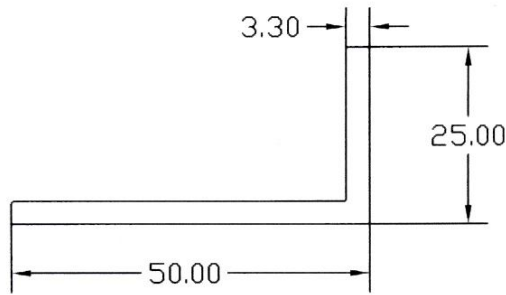

SECTION NO.	T	WEIGHT-RANGE KG/12'
5.11	3.30	2.300



**SHIV SHAKTI ALUMINIUM EXTRUSION (P) LTD.**



An ISO 9001 : 2008 Certified Company



Angle - Fluted Angle

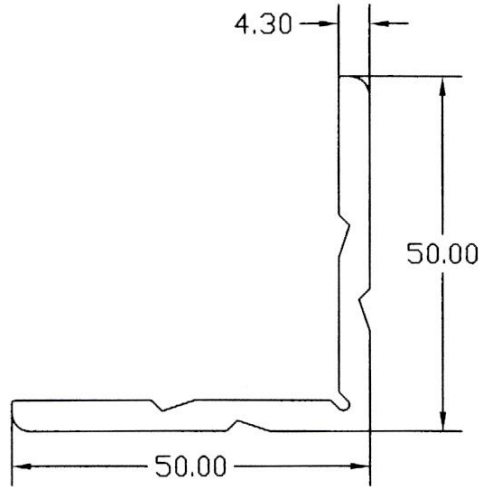

SECTION NO.	T	WEIGHT-RANGE KG/12'
521	4.30	3.800

SHIV SHAKTI ALUMINIUM EXTRUSION (P) LTD.



An ISO 9001 : 2008 Certified Company



**Flat Bars**

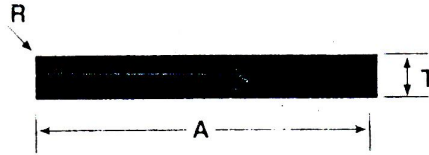

SECTION NO.	A	T	WEIGHT-RANGE KG/12'
601	17	4.00	0.666
602	101.60	9.00	9.750
603	101.60	12.70	12.750

**Flat Bars**

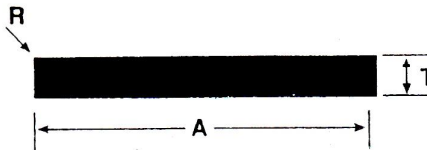

SECTION NO.	A	T	WEIGHT-RANGE KG/12'
604	75.00	12.00	9.500
605	75.00	9.00	7.500

SHIV SHAKTI ALUMINIUM EXTRUSION (P) LTD.





**Flat Bars**

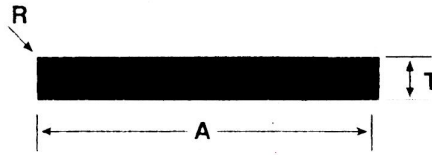

SECTION NO.	A	T	WEIGHT - RANGE KG/12'
606	50.80	12.30	6.200
607	50.80	9.20	4.650
608	50.80	6.00	3.000

**Flat Bars**

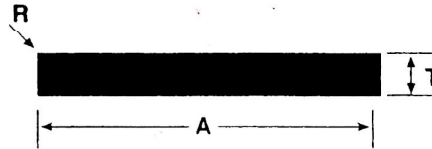

SECTION NO.	A	T	WEIGHT - RANGE KG/12'
609	40.00	9.20	3.500
610	40.00	6.10	2.300
611	25.00	6.40	1.600
612	25.00	3.20	0.800



An ISO 9001 : 2008 Certified Company



**DLE No - 613**

**Cooker Patts**

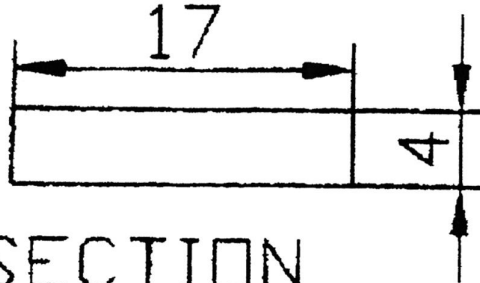

SECTION

WEIHT -0.736-KGS -12'

**DLE No - 614**

**Cooker Patts**

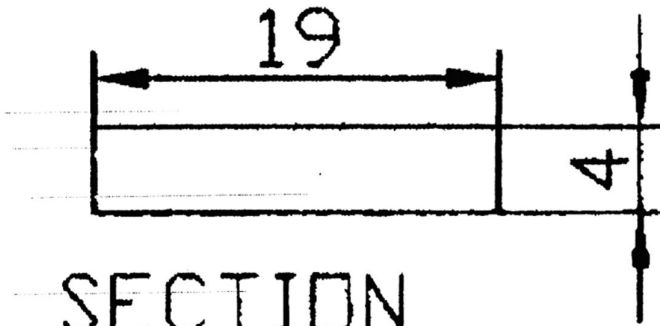

SECTION

HT -0.736-KGS -12'

SHIV SHAKTI ALUMINIUM EXTRUSION (P) LTD.



An ISO 9001 : 2008 Certified Company

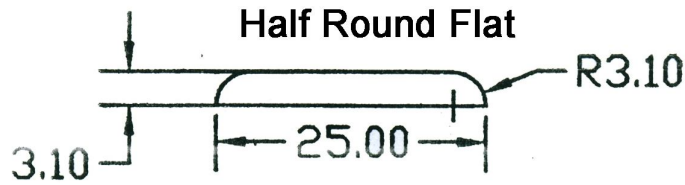

SECTION NO.	T	WEIGHT-RANGE KG/12
701	3.10	.0725

DIL NO- 711

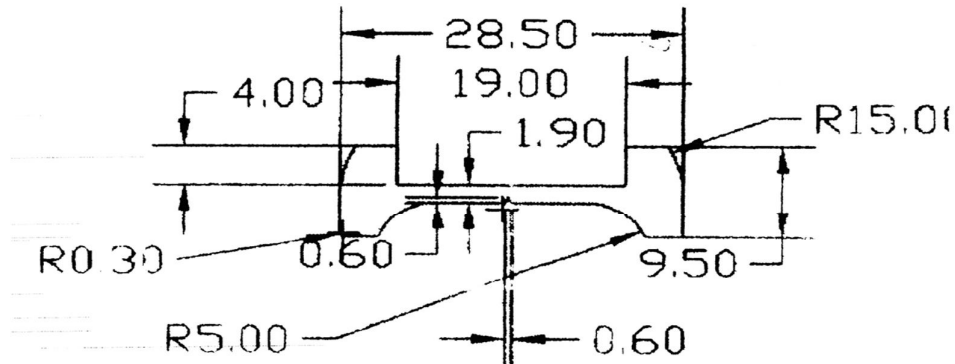

SECTION  
W-1180-12'

Round Flat

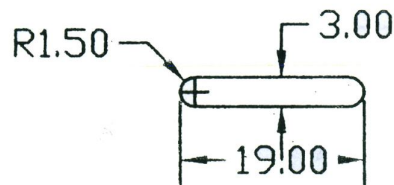

SECTION NO.	T	WEIGHT-RANGE KG/12
801	3mm	0.550

SHIV SHAKTI ALUMINIUM EXTRUSION (P) LTD.



An ISO 9001 : 2008 Certified Company



**Round Rods**

**WEIGHT - RANGE  
KG/12**

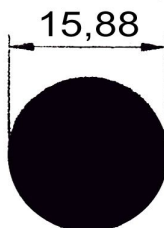

SECTION NO.	ROD SIZE	WEIGHT-RANGE KG/12
901	15.88mm	1.940
902	19.10mm	2.800
903	20.00mm	3.00
904	21.00mm	3.394
905	22.00mm	3.725
906	22.20mm	3.792
907	23.00mm	4.071
908	25.40mm	4.965
909	27.00mm	5.610
910	28.2mm	6.121

**Hexagonal Bars**

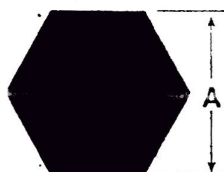

SECTION NO.	2.00MM A	WEIGHT-RANGE KG/12
931	15.87	2.250
932	19.10	3.100
933	24.00	4.800

**SHIV SHAKTI ALUMINIUM EXTRUSION (P) LTD.**



An ISO 9001 : 2008 Certified Company



Star Bars

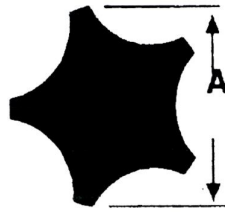

SECTION NO.	T	WEIGHT-RANGE KG/12'
941	32.00	4.900

Single Partition

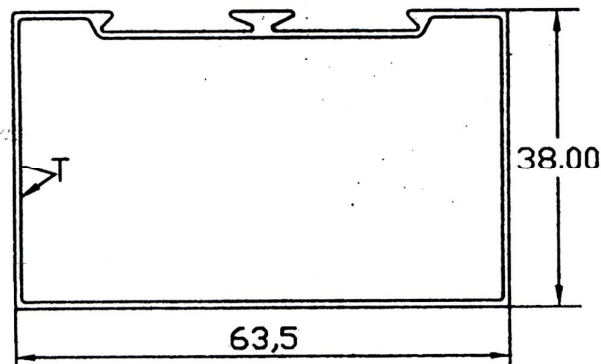

SECTION NO.	T	WEIGHT-RANGE KG/12'
1001	0.70	1.500 - 1.750
1002	0.80	1.700 - 1.950
1003	0.90	1.900 - 2.150
1004	1.00	2.100 - 2.350
1005	1.13	2.40 - 2.650
1006	1.4	2.90 - 3.60
1007	2.00	4.10- 4.350
1008	2.800	5.750-6.150

SHIV SHAKTI ALUMINIUM EXTRUSION (P) LTD.





An ISO 9001 : 2008 Certified Company



**Double Partition**

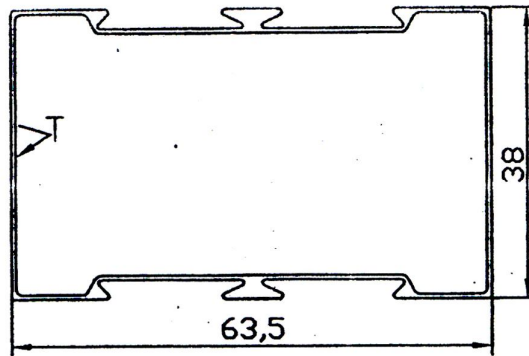

SECTION NO.	T	WEIGHT-RANGE KG/12'
1021	0.65	1.500 - 1.750
1022	0.70	1.700 - 1.950
1023	0.80	1.900 - 2.150
1024	0.95	2.100 - 2.350
1025	1.04	2.40 - 2.650
1026	1.30	2.90 - 3.60
1027	1.90	4.100 - 4.350
1028	2.80	5.750 - 6.150

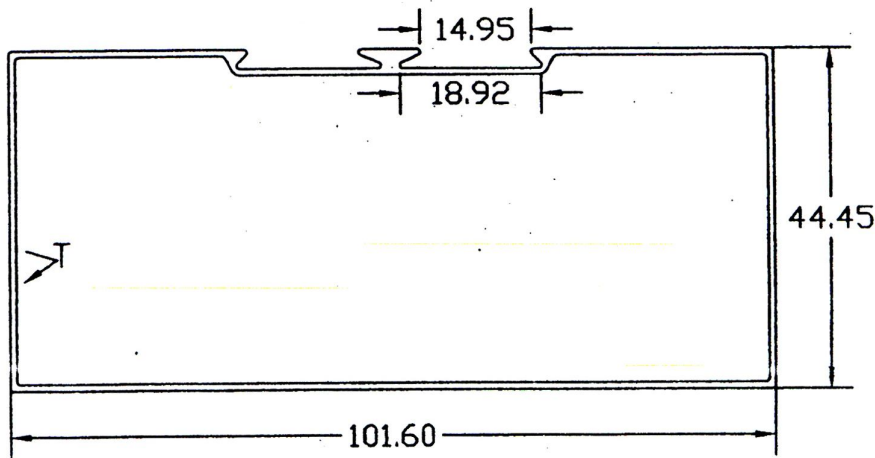

**Single Partition**

SECTION NO.	T	WEIGHT-RANGE KG/12'
1031	1.31	4.00 - 4.200
1032	1.65	4.850 - 5.100
1033	1.75	5.500 - 6.000
1034	2.55	7.500-8.000

**SHIV SHAKTI ALUMINIUM EXTRUSION (P) LTD.**



An ISO 9001 : 2008 Certified Company

Double Partition

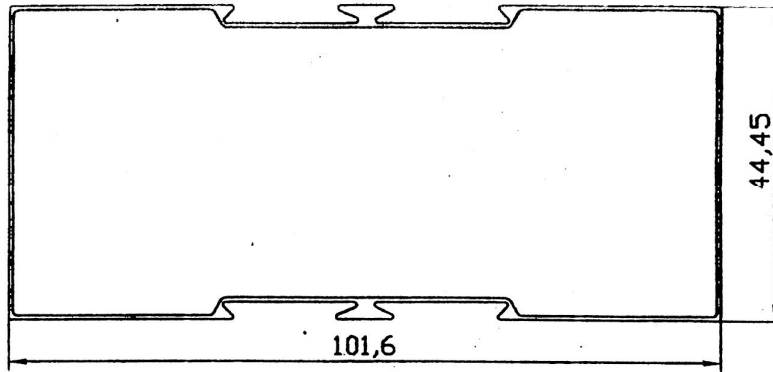

SECTION NO.	T	WEIGHT-RANGE KG/12'
1041	1.20	4.00 - 4.200
1042	1.53	4.850 - 5.10
1043	1.70	5.500 - 6.000
1044	2.53	7.500 - 8.000

Door Vertical

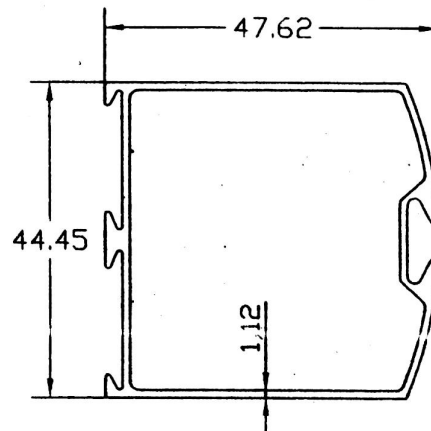

SECTION NO.	T	WEIGHT-RANGE KG/12'
1051	1.00	2.200-2.400
1052	1.12	2.400-2.500



SHIV SHAKTI ALUMINIUM EXTRUSION (P) LTD.

Door Vertical

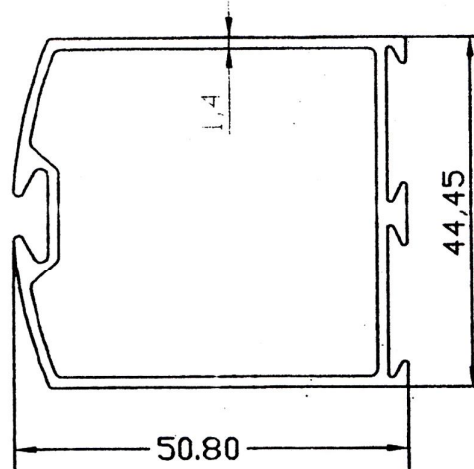

SECTION NO.	T	WEIGHT-RANGE KG/12'
1061	1.4	3.158 - 3.300
1062	2.4	4.600 - 5.500

Door Vertical

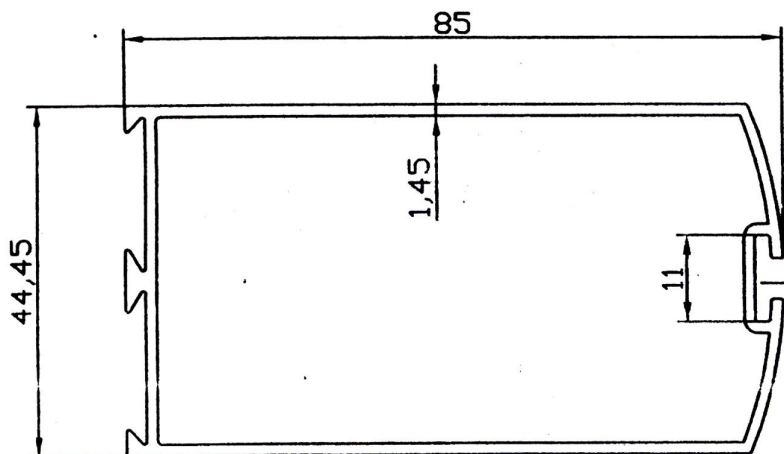

WEIGHT - 3.840 - KGS - 12'

SECTION NO.	T	WEIGHT-RANGE KG/12'
1071	1.45	3.840 - 3.950
1072	2.8	7.000- 7.500







An ISO 9001 : 2008 Certified Company



**Door Middle Single**

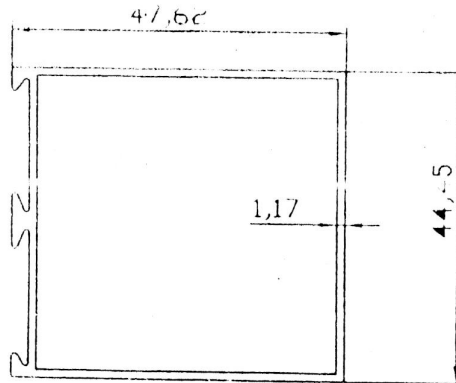

SECTION NO.	T	WEIGHT-RANGE KG/12'
1081	1.17	2.250 - 2.350

**Door Bottam**

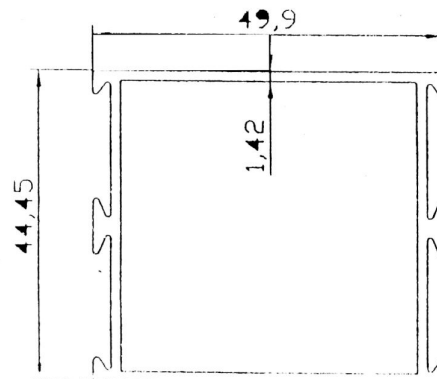

SECTION NO.	T	WEIGHT-RANGE KG/12'
1091	1.1	2.250 - 2.350
1092	1.42	2.900 -3.100

**SHIV SHAKTI ALUMINIUM EXTRUSION (P) LTD.**



An ISO 9001 : 2008 Certified Company

Door Middle Double

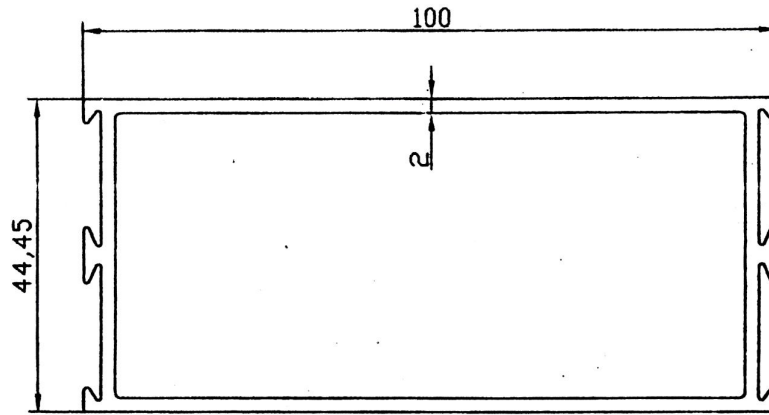

SECTION NO.	T	WEIGHT-RANGE KG/12'
1101	2.MM	5.800 - 6.150

Door Top

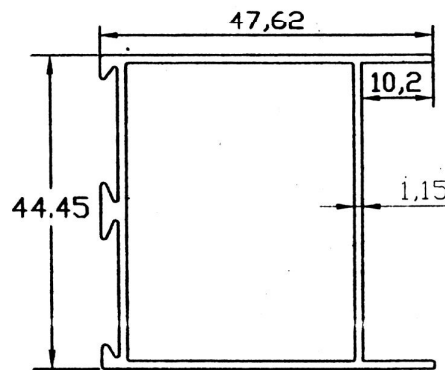

SECTION NO.	T	WEIGHT-RANGE KG/12'
1111	1.15	2.250 - 2.350
1112	1.55	2.900- 3.150



SHIV SHAKTI ALUMINIUM EXTRUSION (P) LTD.



An ISO 9001 : 2008 Certified Company



Door Top

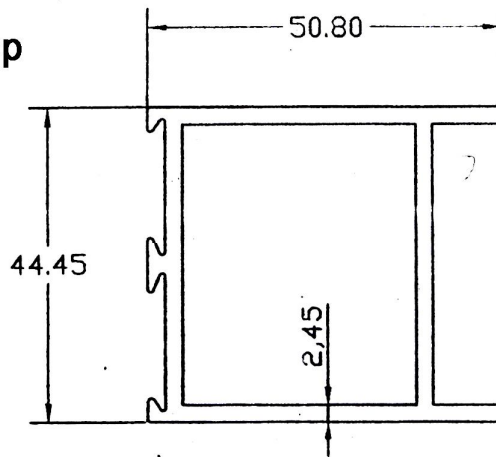

SECTION NO.	T	WEIGHT-RANGE KG/12'
1121	2.45	4.500 - 4.600

Door Bottom

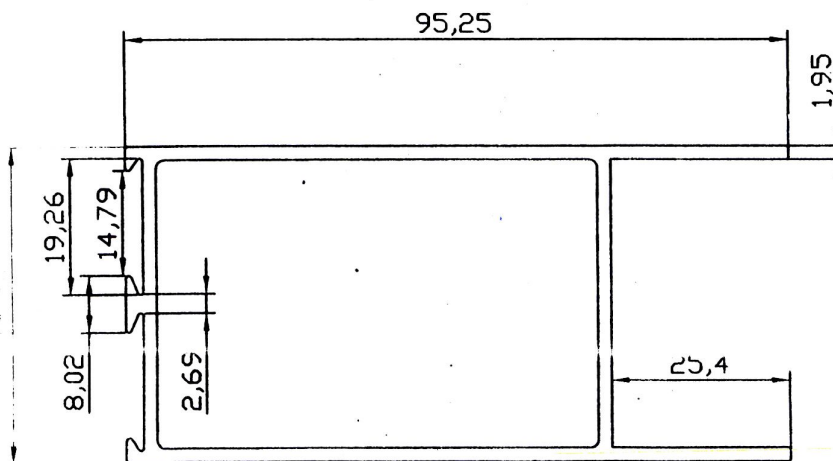

SECTION NO.	T	WEIGHT-RANGE KG/12'
1131	1.45	4.000 - 4.500
1132	1.95	5.500 - 6.000

SHIV SHAKTI ALUMINIUM EXTRUSION (P) LTD.



An ISO 9001 : 2008 Certified Company

Door Bottam

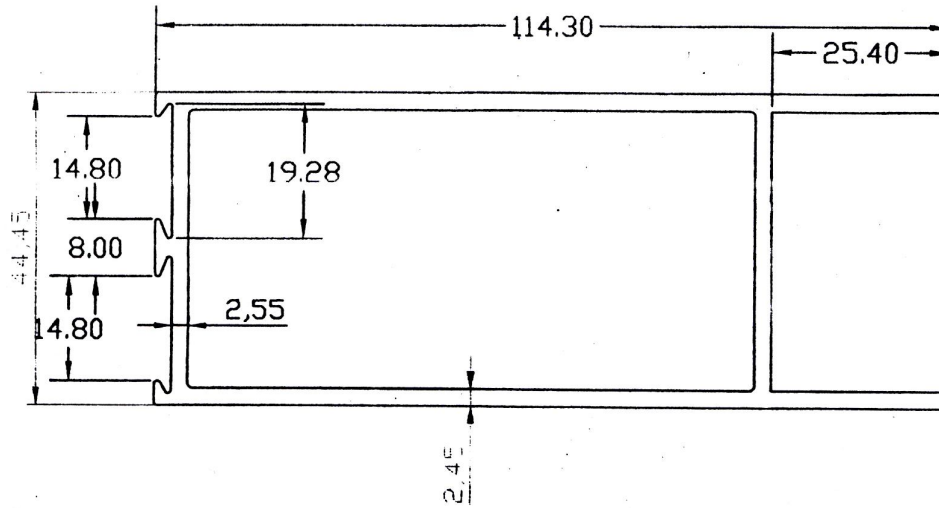

SECTION NO.	T	WEIGHT-RANGE KG/12'
1141	2.450	7.100 - 7.300

Door Top

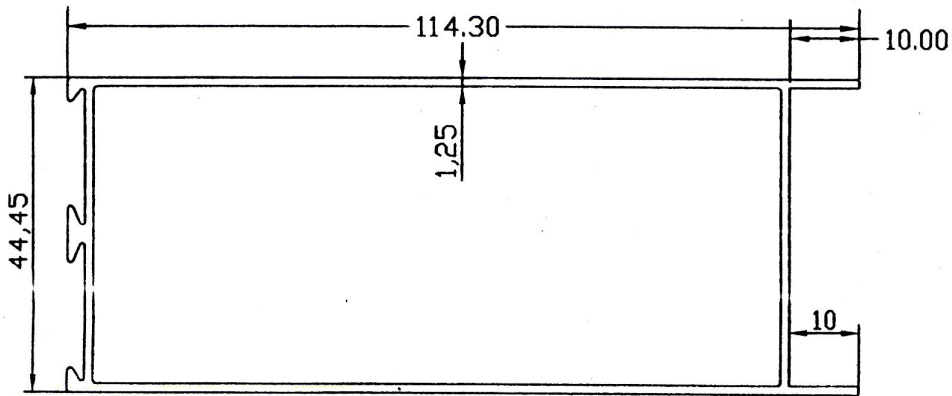

SECTION NO.	T	WEIGHT-RANGE KG/12'
1151	1.25	4.00 - 4.150



SHIV SHAKTI ALUMINIUM EXTRUSION (P) LTD.



An ISO 9001 : 2008 Certified Company



Sold Glass Section

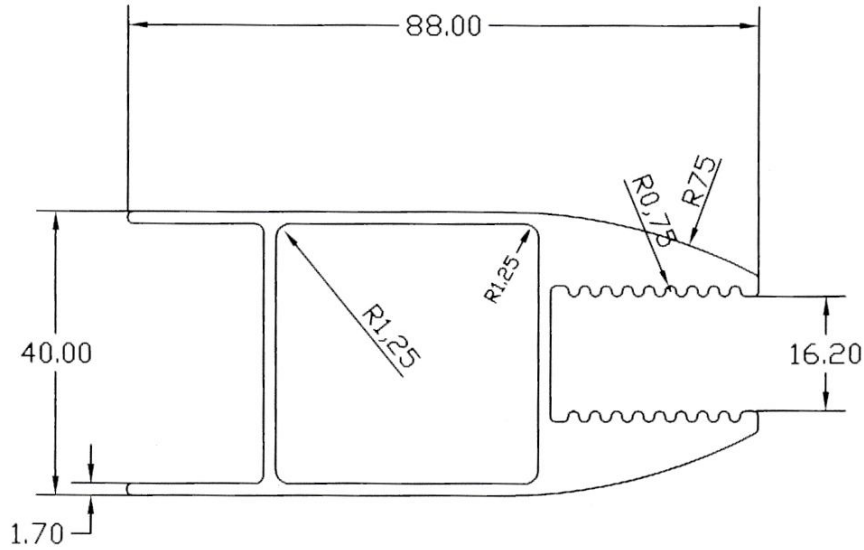

SECTION NO.	T	WEIGHT-RANGE KG/12'
1161	1.70	7.500

SHIV SHAKTI ALUMINIUM EXTRUSION (P) LTD.



Topper Clip

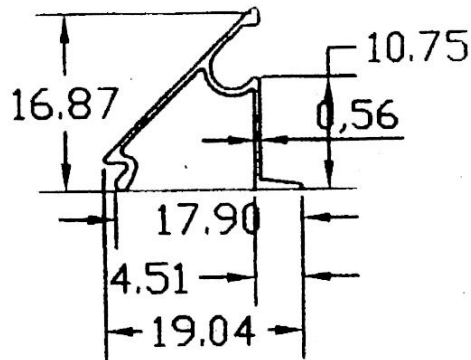

SECTION NO.	T	WEIGHT-RANGE KG/12'
1201	0.50	0.150 - 0.280
1202	0.60	0.280 - 0.310
1203	0.65	0.310 - 0.350
1204	0.80	0.350 - 0.380

Rectangular Tube 2/1

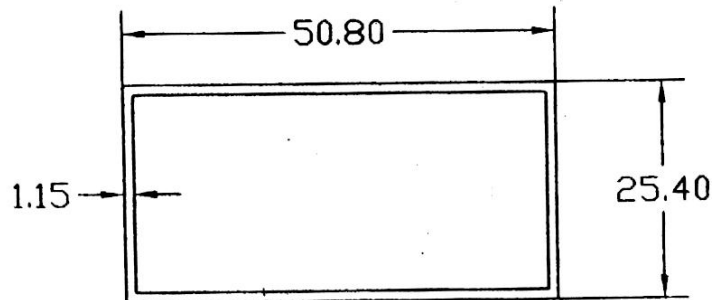

SECTION NO.	T	WEIGHT-RANGE KG/12'
1301	1.10	1.700 - 1.850



Rectangular Tube

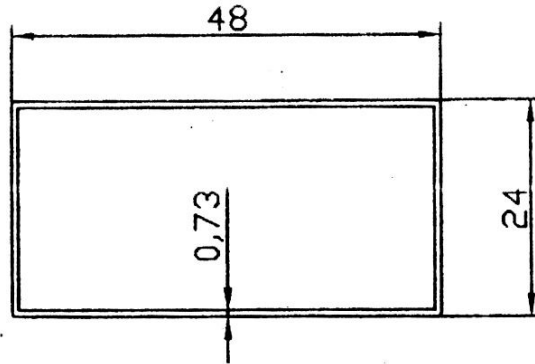

SECTION NO.	T	WEIGHT-RANGE KG/12'
1322	0.73	100 -1.250
1313	0.90	1.250 - 1.450
1314	1.05	1.450 - 1.600
1315	1.33	1.800 - 2.000

Rectangular Tube

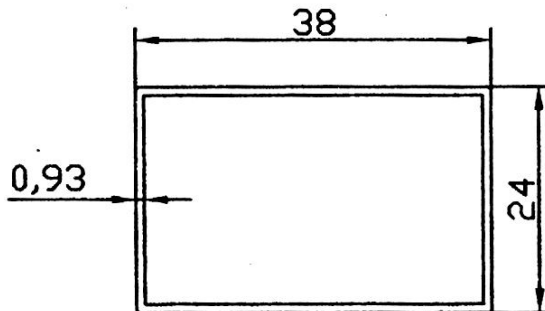

SECTION NO.	T	WEIGHT-RANGE KG/12'
1331	0.6	0.750 -0.850
1332	0.8	0.850 - 1.000
1333	0.93	1.000 - 1.250
1334	1.07	1.250 - 1.350





Rectangular Tube

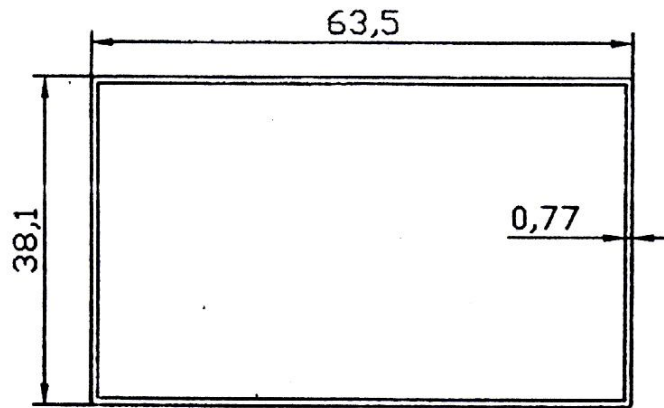

SECTION NO.	T	WEIGHT-RANGE KG/12'
1341	0.77	1.500 - 1.650
1342	0.85	1.670 - 1.750
1343	0.90	1.800 - 1.950
1344		3.000 - 3.400

Rectangular Tube

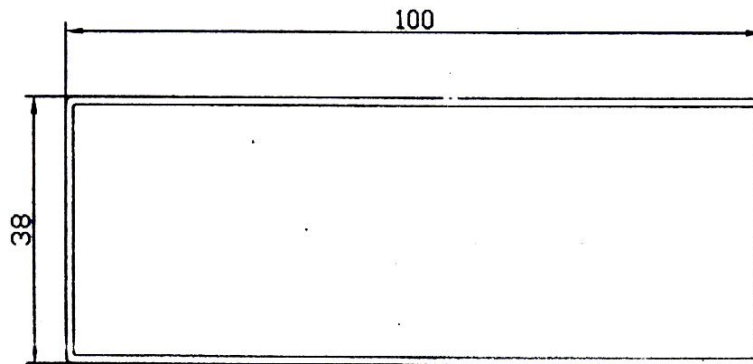

SECTION NO.	T	WEIGHT-RANGE KG/12'
1351	1.13	3.00 - 3.150





Rectangular Tube

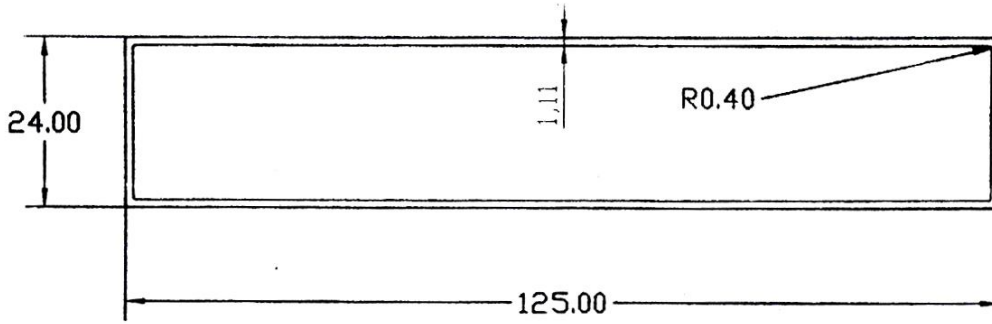

SECTION NO.	T	WEIGHT-RANGE KG/12'
1356	1.1	3.200 - 3.350

Rectangular Tube

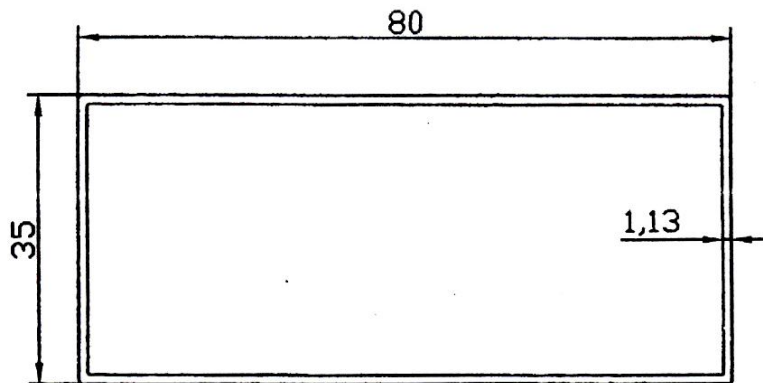

SECTION NO.	T	WEIGHT-RANGE KG/12'
1361	1.1	2.400 - 2.600
1362	1.15	2.600 - 2.850
1363	1.3	2.850 - 3.100



Squarc Tube

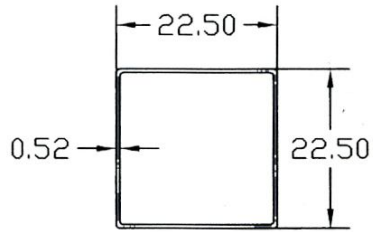

SECTION NO.	T	WEIGHT-RANGE KG/12'
1366	0.52	0.450 - 0.500

Squarc Tube

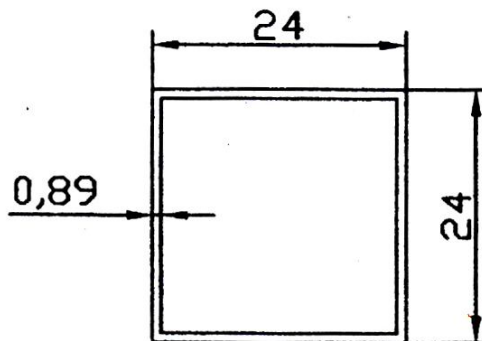

SECTION NO.	T	WEIGHT-RANGE KG/12'
1371	0.89	0.800 - 0.950



Squarc Tube

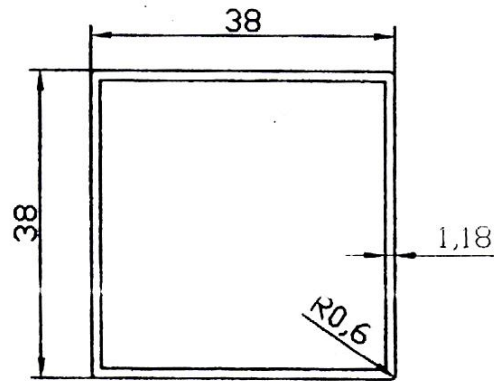

SECTION NO.	T	WEIGHT-RANGE KG/12'
1381	1.18	1.700 - 1.850

Squarc Tube

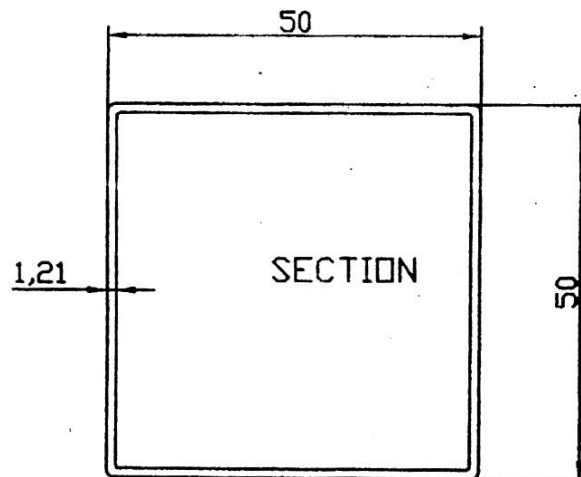

SECTION NO.	T	WEIGHT-RANGE KG/12'
1391	1.21	2.300 - 2.500



Fluted Round Pipe

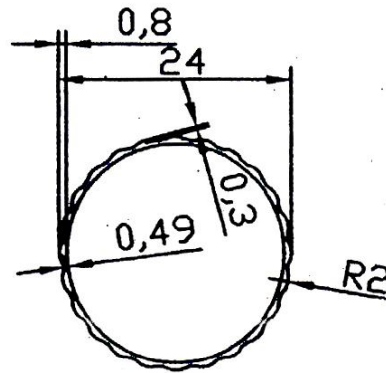

SECTION NO.	T	WEIGHT-RANGE KG/12'
1401	0.50	0.450 - 0.500
1402	0.55	0.500 - 0.550
1403	0.60	0.550 - 0.600

Handle

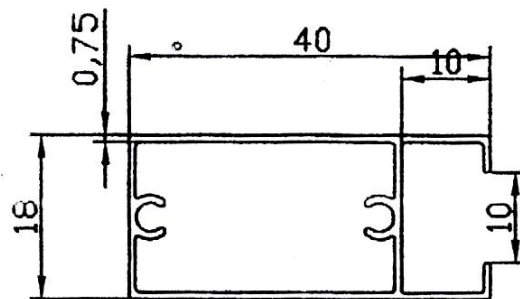

SECTION NO.	T	WEIGHT-RANGE KG/12'
1501	0.75	1.00 - 1.150
1502	0.950	1.250 - 1.400
1503	1.13	1.450 - 1.550
1504	1.25	1.550 - 1.800
1505	1.50	1.800 - 2.250



Top Bottom

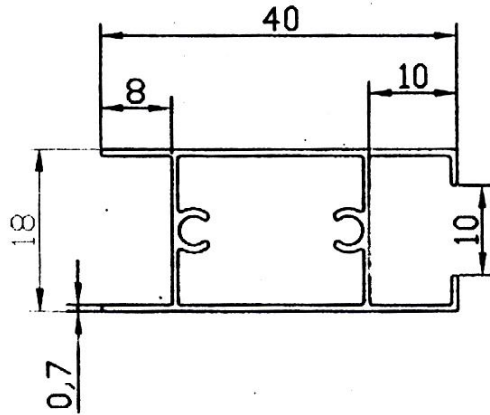

SECTION NO.	T	WEIGHT-RANGE KG/12'
1511	0.750	1.00 - 1210
1512	0.90	1.200 - 1.500
1513	1.1	1.500 - 1.750
1514	1.45	1.800 - 2.250

Interlock

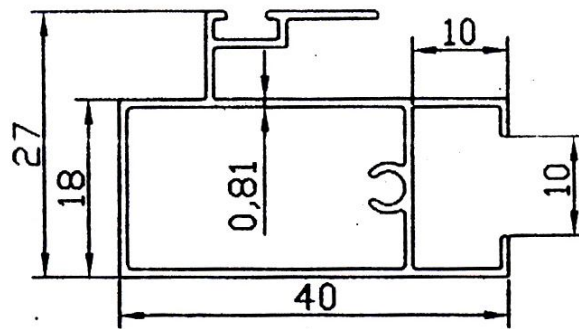

SECTION NO.	T	WEIGHT-RANGE KG/12'
1521	0.80	1.250 - 1.400
1552	0.950	1.450 - 1.600
1553	1.10	1.600 -1.850
1554	1.45	2.100 - 2.500



Bearing Bottam

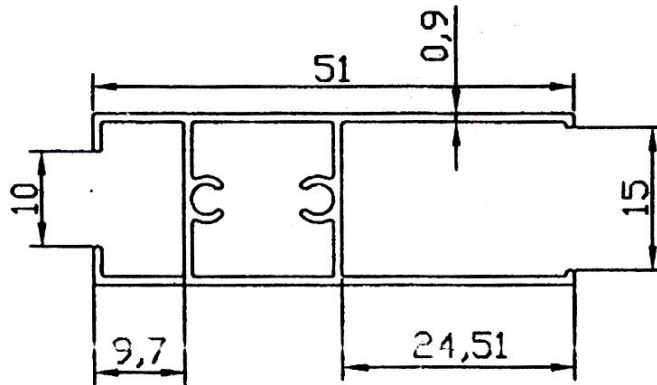

SECTION NO.	T	WEIGHT-RANGE KG/12'
1531	0.90	1.400 - 1.550
1532	1.10	1.700 - 1.850

Interlock

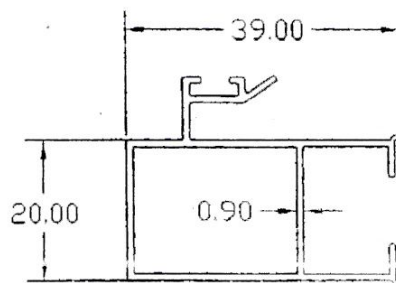

SECTION NO.	T	WEIGHT-RANGE KG/12'
1541	0.8	1.200 - 1.500
1542	1.0	1.500 - 1.800





An ISO 9001 : 2008 Certified Company

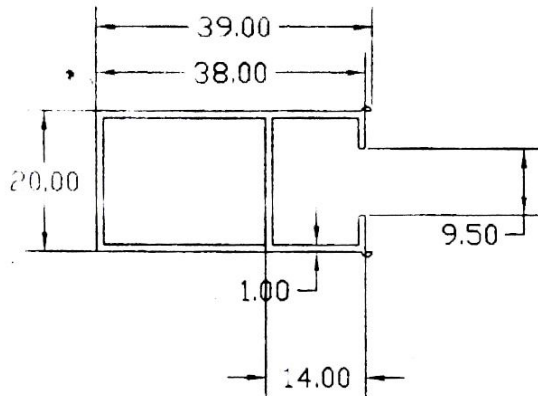

SECTION NO.	T	WEIGHT-RANGE KG/12'
1551	0.9	1.100 - 1.350
1552	1.0	1.350 - 1.600

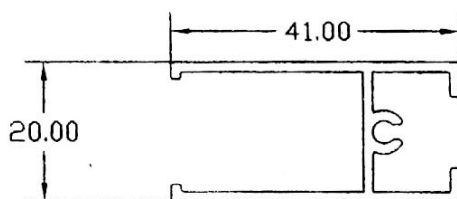

SECTION NO.	T	WEIGHT-RANGE KG/12'
1561	0.9	1.100 - 1.350
1562	1.4	1.600 - 1.900

SHIV SHAKTI ALUMINIUM EXTRUSION (P) LTD.



Handle

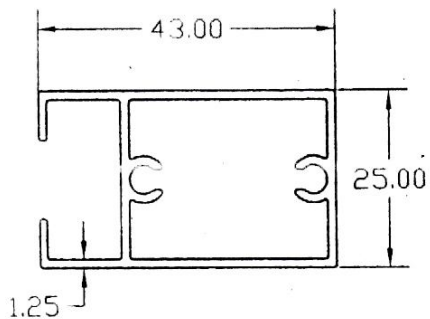

SECTION NO.	T	WEIGHT-RANGE KG/12'
1571	1.25	2.00 - 2.350

Top Bottom

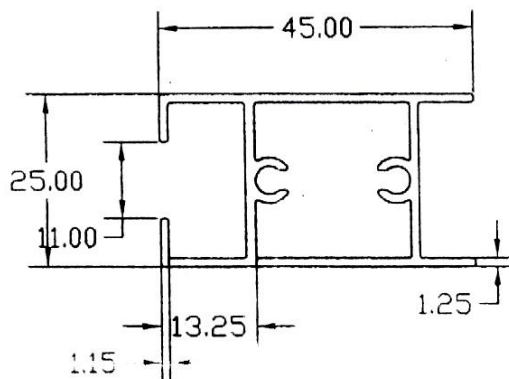

SECTION NO.	T	WEIGHT-RANGE KG/12'
1576	1.25	2.100 - 2.350





Handle

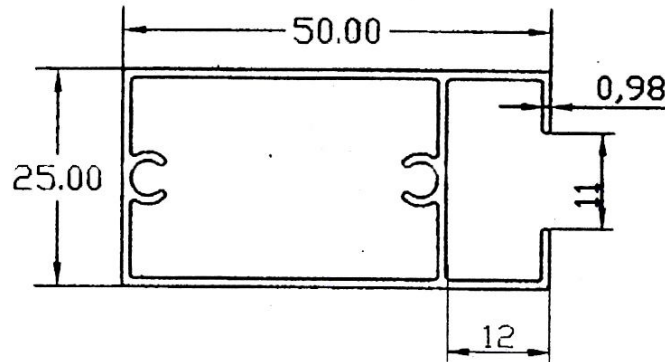

SECTION NO.	T	WEIGHT-RANGE KG/12'
1581	0.98	1.700 - 1.850
1582	1.10	1.900 - 2.100

Interlock

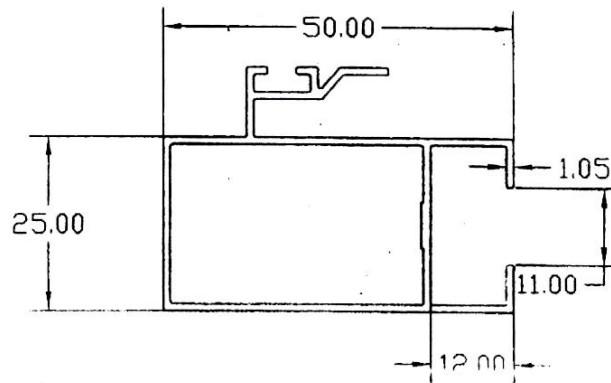

SECTION NO.	T	WEIGHT-RANGE KG/12'
1586	1.050	2.100 - 2.350



An ISO 9001 : 2008 Certified Company



Top Bottom

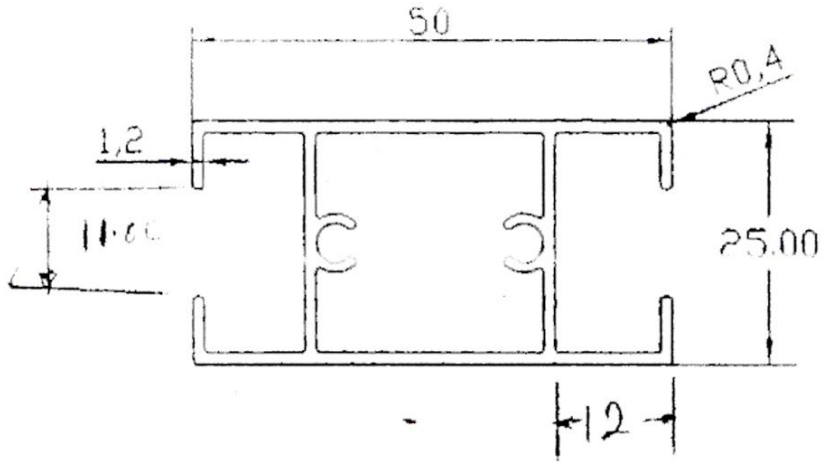

SECTION NO.	T	WEIGHT-RANGE KG/12'
1591	1.20	2.200 - 2.400

SHIV SHAKTI ALUMINIUM EXTRUSION (P) LTD.



Round Pipe

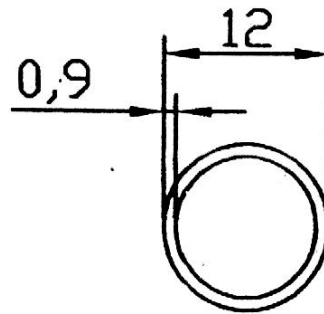

SECTION NO.	T	WEIGHT-RANGE KG/12'
1601	0.90	0.300 - 0.450

Round Pipe

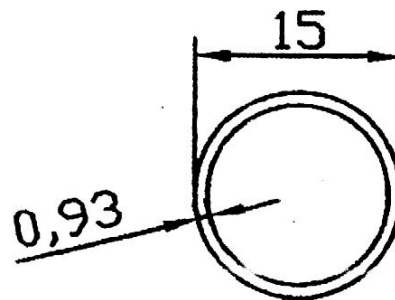

SECTION NO.	T	WEIGHT-RANGE KG/12'
1606	0.93	0.400 - 0.550



Round Pipe

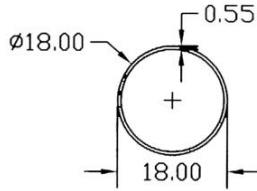

SECTION NO.	T	WEIGHT-RANGE KG/12'
1611	0.55	0.350 - 0.400

Round Pipe

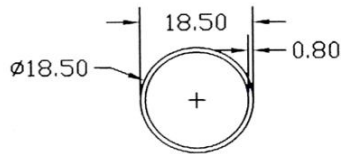

SECTION NO.	T	WEIGHT-RANGE KG/12'
1615	0.80	0.45 - 0.5.00

Round Pipe

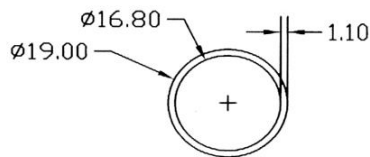

SECTION NO.	T	WEIGHT-RANGE KG/12'
1616	1.10	0.600 - 0.650



Round Pipe

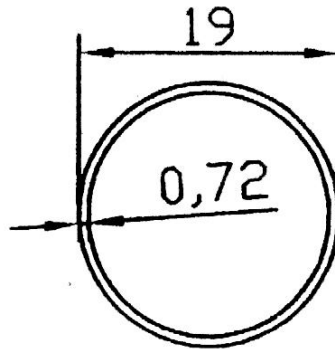

SECTION NO.	T	WEIGHT-RANGE KG/12'
1621	0.70	4.000 - 0.500
1622	0.80	0.450 - 0.550
1623	0.90	0.500 - 0.650
1624	1.1	0.600 - 0.650

Round Pipe

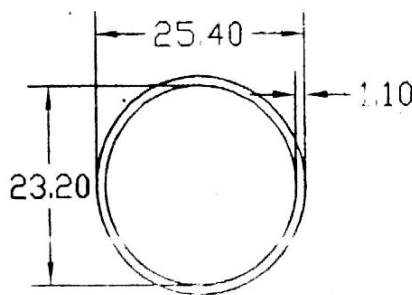

SECTION NO.	T	WEIGHT-RANGE KG/12'
1626	1.1	0.825 - 0.950



An ISO 9001 : 2008 Certified Company



Round Pipe

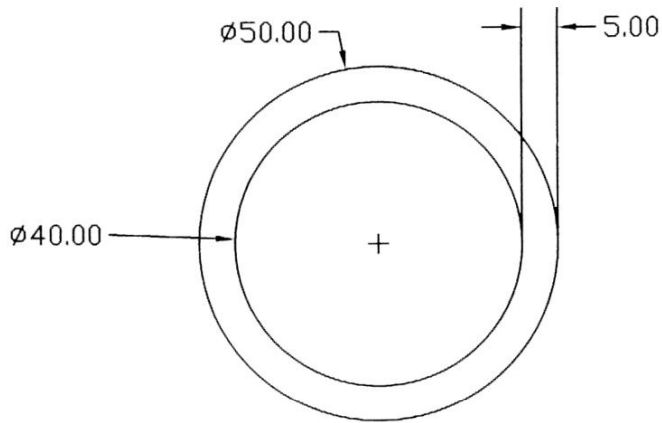

SECTION NO.	T	WEIGHT-RANGE KG/12'
1631	5.00	6.800
1632	5.9	8.00 - 8.500

Round Pipe

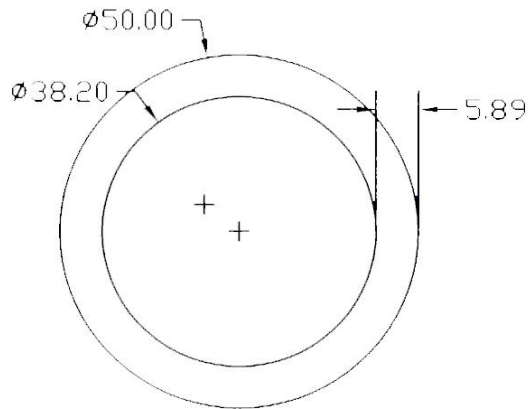

SECTION NO.	T	WEIGHT-RANGE KG/12'
1636	5.90	8.00 - 8.200

SHIV SHAKTI ALUMINIUM EXTRUSION (P) LTD.

Irrigation Tube

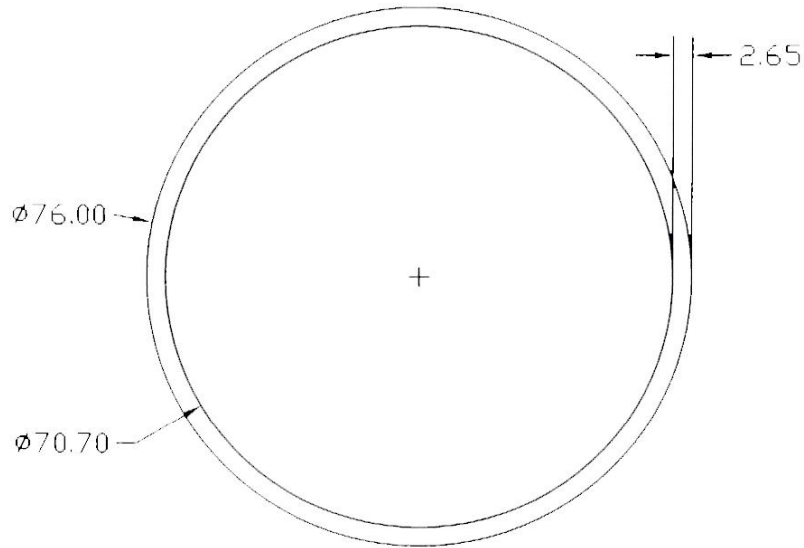

SECTION NO.	T	WEIGHT-RANGE KG/12'
1641	2.65	6.00

Two Track Top

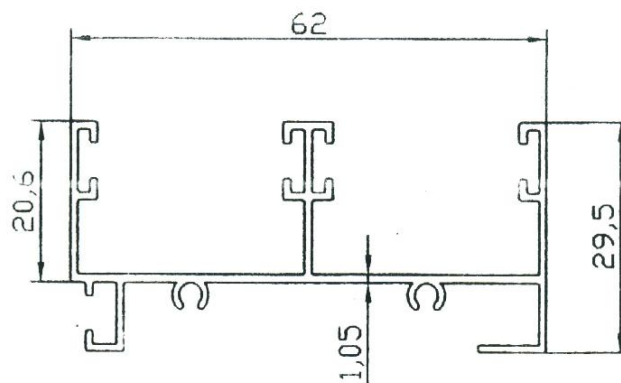

SECTION NO.	T	WEIGHT-RANGE KG/12'
1701	0.8	1.650 - 2.000
1702	1.05	2.000 - 2.250
1703	1.1	2.250 - 2.500
1704	1.5	2.500 - 3.000







Two Track Bottom

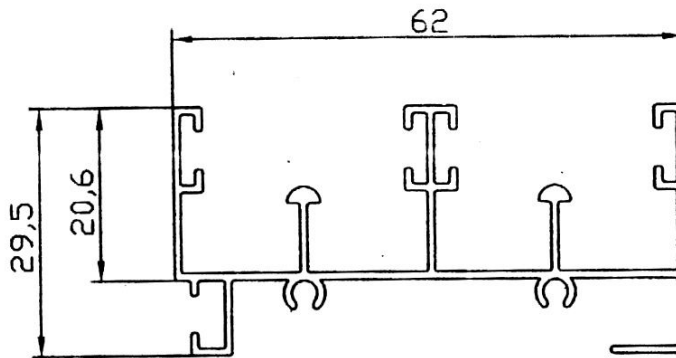

SECTION NO.	T	WEIGHT-RANGE KG/12'
1711	0.9	1.900 - 2.225
1712	.950	2.000 - 2.550
1713	1.1	2.450 - 2.750
1714	1.50	3.225 - 3.550

Three Track Top

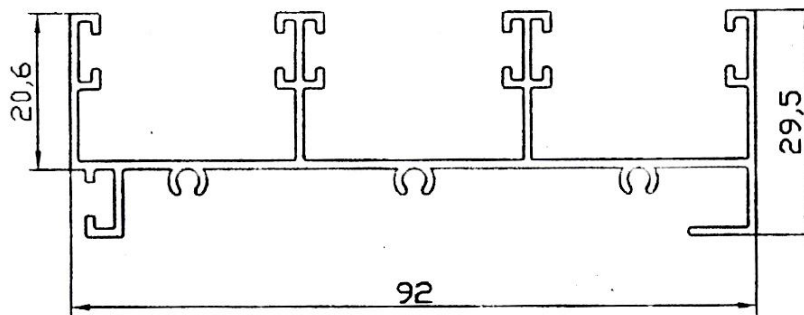

SECTION NO.	T	WEIGHT-RANGE KG/12'
1721	.80	2.300 - 2.600
1722	.90	2.600 - 3.000
1723	1.15	3.000 - 3.500
1724	1.50	3.500 - 4.500





Three Track Bottom

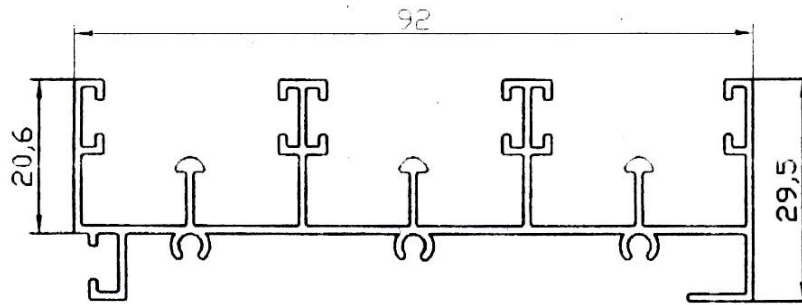

SECTION NO.	T	WEIGHT-RANGE KG/12'
1731	.80	2.750 - 2.750
1732	.90	2.950 - 3.350
1733	1.10	3.350 - 3.550
1734	1.50	4.250 - 4.750

Three Track Top

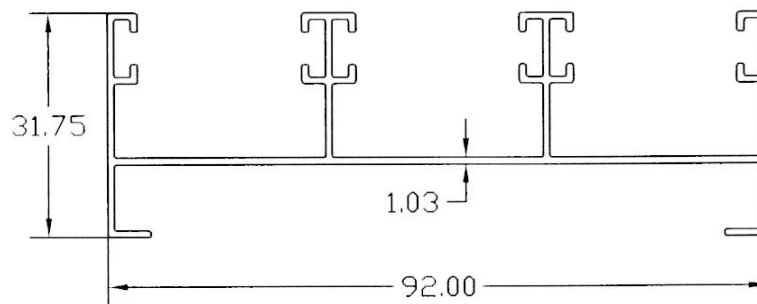

SECTION NO.	T	WEIGHT-RANGE KG/12'
1741	0.80	2.000 - 2.500
1742	1.00	2.500 - 3.000
1743	1.5	3.000 - 3.700



An ISO 9001 : 2008 Certified Company



Two Track Top

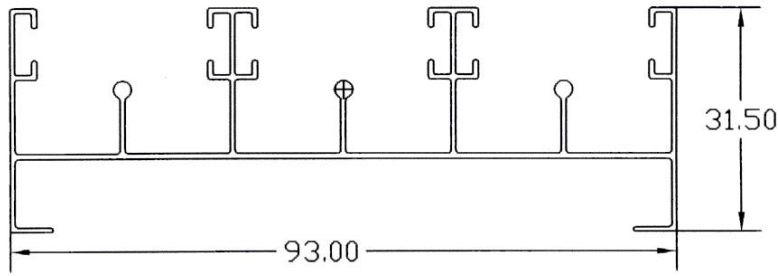

SECTION NO.	T	WEIGHT-RANGE KG/12'
1751	0.70	2.200 - 2.700
1752	0.90	2.700 - 3.500
1753	1.5	4.000 - 4.500

Two Track Top

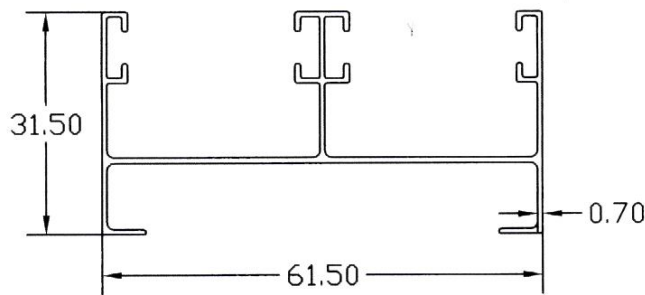

SECTION NO.	T	WEIGHT-RANGE KG/12'
1761	0.70	1.400 - 1.700
1762	1.10	1.700 - 2.500
1763	1.50	2.500 - 3.000

SHIV SHAKTI ALUMINIUM EXTRUSION (P) LTD.



An ISO 9001 : 2008 Certified Company



### Two Track Bottom

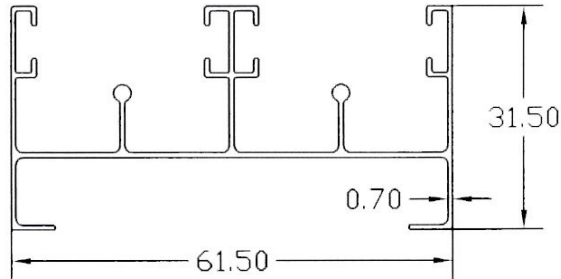

SECTION NO.	T	WEIGHT-RANGE KG/12'
1771	0.70	1.650 - 1.850
1772	1.1	1.850 - 2.250
1773	1.5	<b>3.000-3.500</b>

SHIV SHAKTI ALUMINIUM EXTRUSION (P) LTD.



An ISO 9001 : 2008 Certified Company



SHIV SHAKTI ALUMINIUM EXTRUSION (P) LTD.

**Bulb tec**

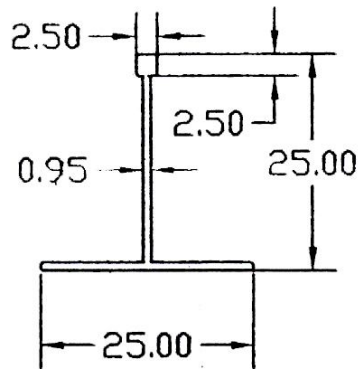

SECTION NO.	T	WEIGHT-RANGE KG/12'
1801	.095	0.500 - 0.650
1802	1.3	0.650 - 0.750
1803	1.45	0.730 - 0.800

**Bulb tec**

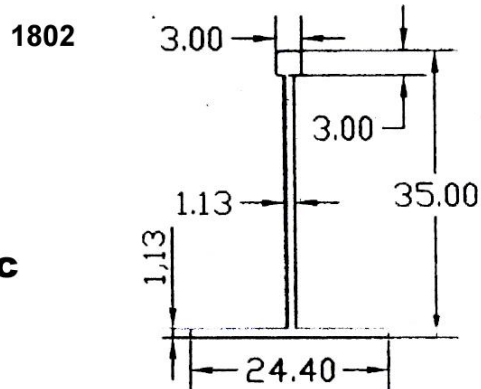

SECTION NO.	T	WEIGHT-RANGE KG/12'
1811	1.13	0.700 - 0.850



An ISO 9001 : 2008 Certified Company



SHIV SHAKTI ALUMINIUM EXTRUSION (P) LTD.

**Bulb tec**

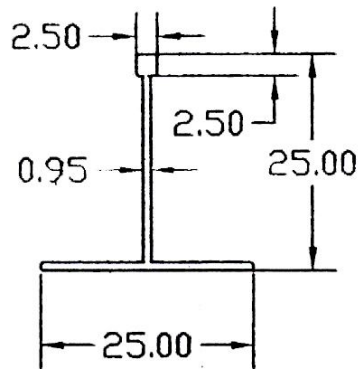

SECTION NO.	T	WEIGHT-RANGE KG/12'
1801	.095	0.500 - 0.650
1802	1.3	0.650 - 0.750
1803	1.45	0.730 - 0.800

**Bulb tec**

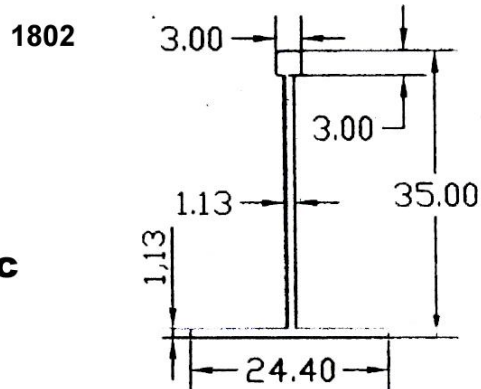

SECTION NO.	T	WEIGHT-RANGE KG/12'
1811	1.13	0.700 - 0.850



An ISO 9001 : 2008 Certified Company



**Blub Tec**

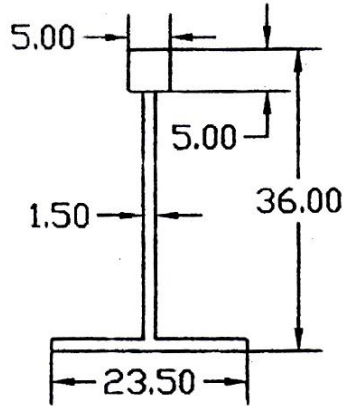

SECTION NO.	T	WEIGHT-RANGE KG/12'
1821	1.5	1.000 - 1.150

**Water Channel**

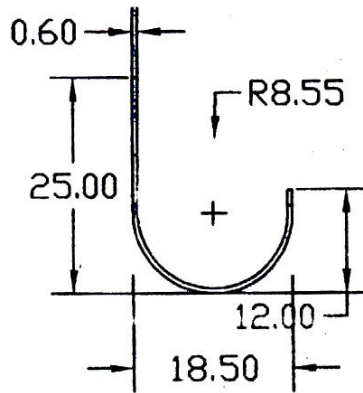

SECTION NO.	T	WEIGHT-RANGE KG/12'
1901	0.60	0.250 - 0.280

SHIV SHAKTI ALUMINIUM EXTRUSION (P) LTD.





An ISO 9001 : 2008 Certified Company



**Water Channel**

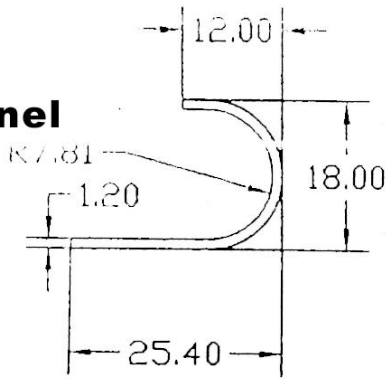

SECTION NO.	T	WEIGHT-RANGE KG/12'
1902	1.2	0.500 - 0.650

**Water Channel**

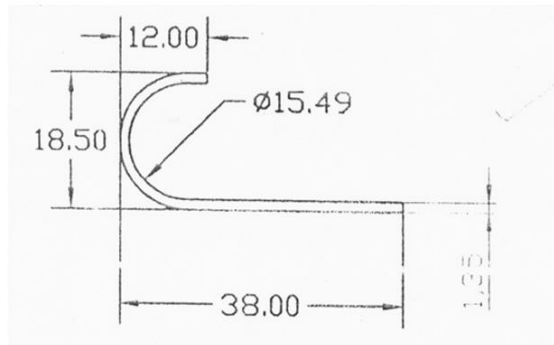

SECTION NO.	T	WEIGHT-RANGE KG/12'
1903	1.35	0.775 - 0.900

SHIV SHAKTI ALUMINIUM EXTRUSION (P) LTD.



An ISO 9001 : 2008 Certified Company



**Water Channel**

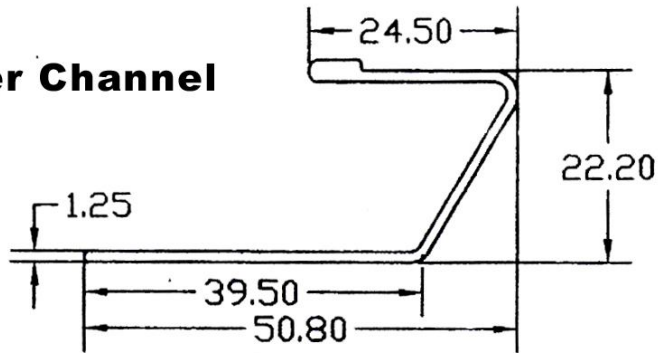

SECTION NO.	T	WEIGHT-RANGE KG/12'
1921	1.25	1.116 - 1.250

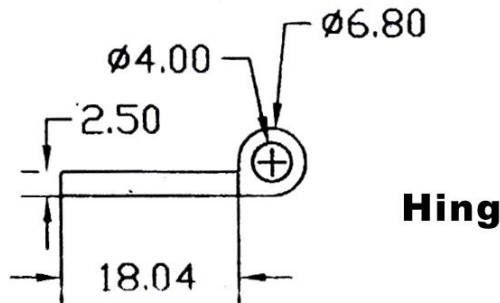

SECTION NO.	T	WEIGHT-RANGE KG/12'
2001	2.50	0.721 - 0.850

SHIV SHAKTI ALUMINIUM EXTRUSION (P) LTD.



An ISO 9001 : 2008 Certified Company



Hing

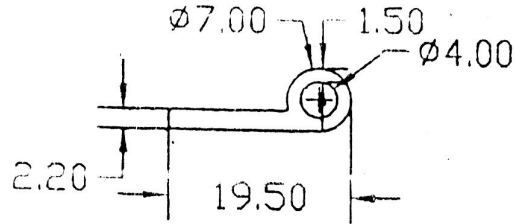

SECTION NO.	T	WEIGHT-RANGE KG/12'
2002	2.20	0.550 - 0.750

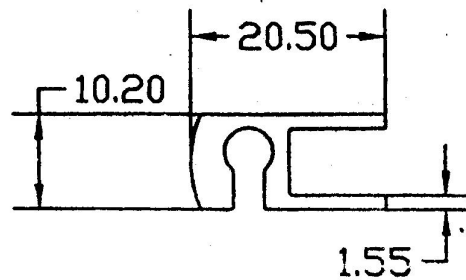

SECTION NO.	T	WEIGHT-RANGE KG/12'
2101	1.55	0.986 - 1.150

SHIV SHAKTI ALUMINIUM EXTRUSION (P) LTD.



An ISO 9001 : 2008 Certified Company

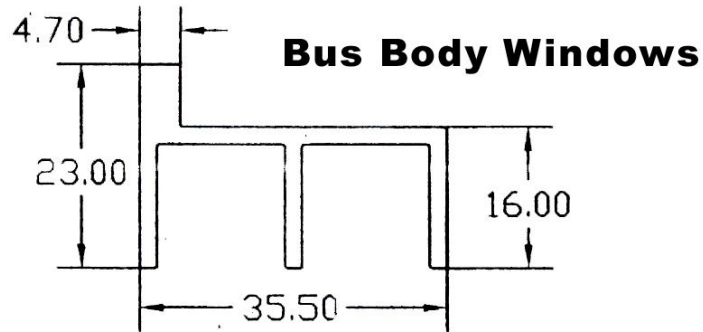

SECTION NO.	T	WEIGHT-RANGE KG/12'
2102	2.00	1.800 - 2.200

**Bus Body Windows**

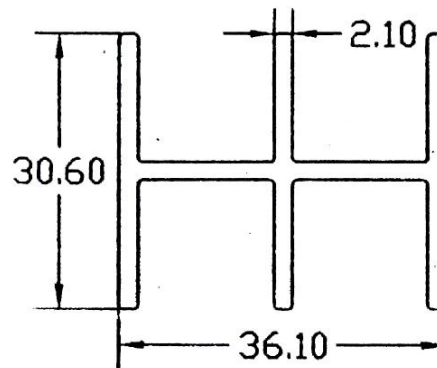

SECTION NO.	T	WEIGHT-RANGE KG/12'
2103	2.00	2.520 - 2.750

**SHIV SHAKTI ALUMINIUM EXTRUSION (P) LTD.**



## Bus Body Windows

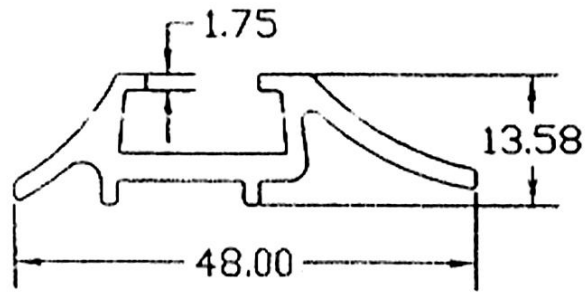

SECTION NO.	T	WEIGHT-RANGE KG/12'
2104	.1.75	1.822 - 2.000

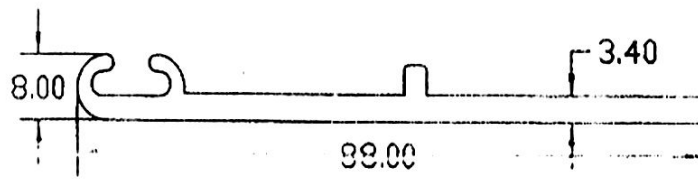

SECTION NO.	T	WEIGHT-RANGE KG/12'
2105	3.40	3.200 - 3.500



An ISO 9001 : 2008 Certified Company

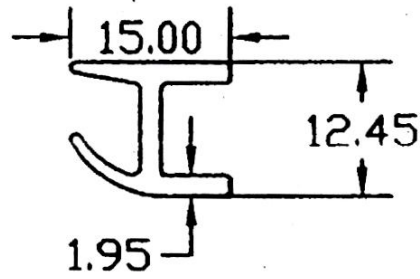

SECTION NO.	T	WEIGHT-RANGE KG/12'
2106	1.95	1.10 - 1.150

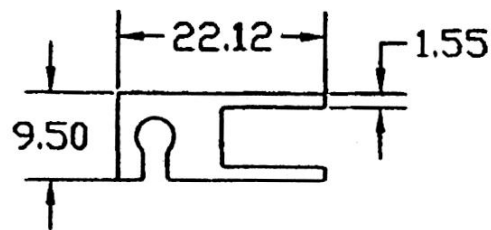

SECTION NO.	T	WEIGHT-RANGE KG/12'
2107	1.55	1.170 - 1.250

SHIV SHAKTI ALUMINIUM EXTRUSION (P) LTD.





An ISO 9001 : 2008 Certified Company

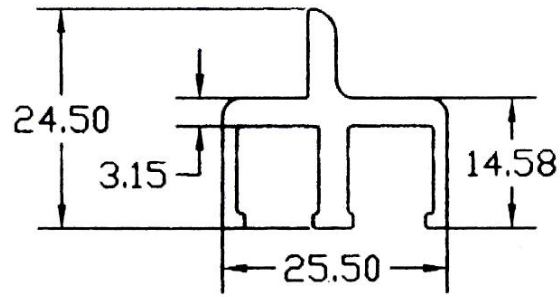

SECTION NO.	T	WEIGHT-RANGE KG/12'
2108	3.15	1.850 - 2.000

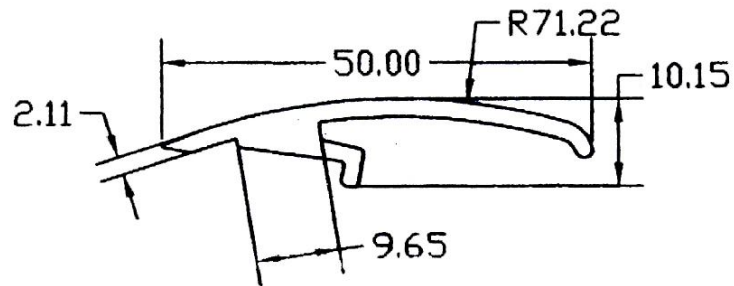

SECTION NO.	T	WEIGHT-RANGE KG/12'
2109	2.11	1.110 - 1.250

SHIV SHAKTI ALUMINIUM EXTRUSION (P) LTD.

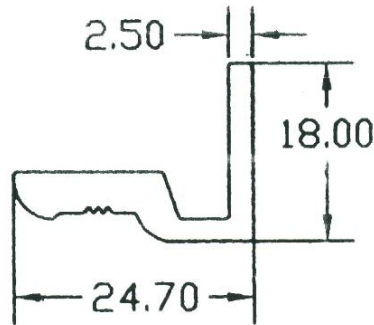

SECTION NO.	T	WEIGHT-RANGE KG/12'
2110	2.50	1.300 - 1.500

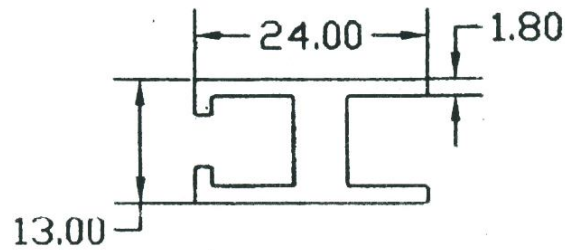

SECTION NO.	T	WEIGHT-RANGE KG/12'
2111	1.80	1.411 - 1.550



An ISO 9001 : 2008 Certified Company

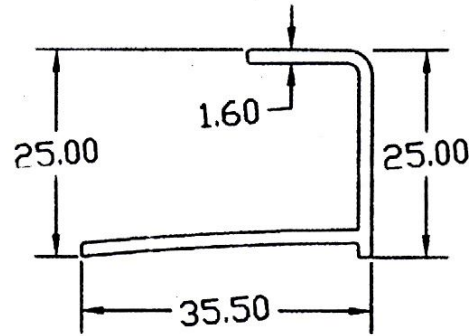

SECTION NO.	T	WEIGHT-RANGE KG/12'
2112	1.60	1.120 - 1.250

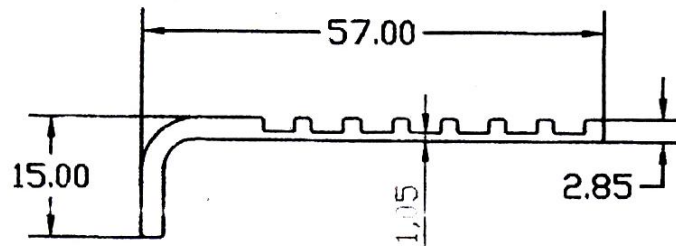

SECTION NO.	T	WEIGHT-RANGE KG/12'
2113	0.95	1.350 - 1.550

SHIV SHAKTI ALUMINIUM EXTRUSION (P) LTD.



An ISO 9001 : 2008 Certified Company

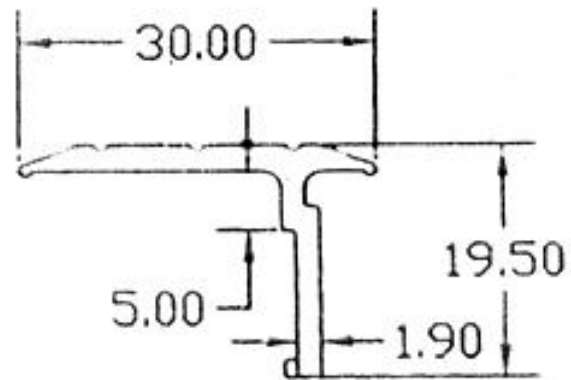

SECTION NO	T	WEIGHT-RANGE KG/12'
2114	1.90	0.941 - 1.150

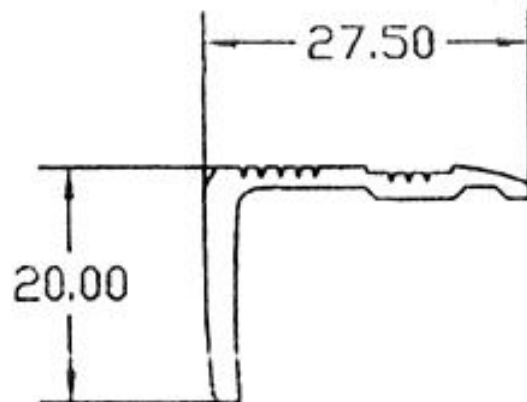

SECTION NO	T	WEIGHT-RANGE KG/12'
2115	1.80	0.925 - 1.150

SHIV SHAKTI ALUMINIUM EXTRUSION (P) LTD.



An ISO 9001 : 2008 Certified Company

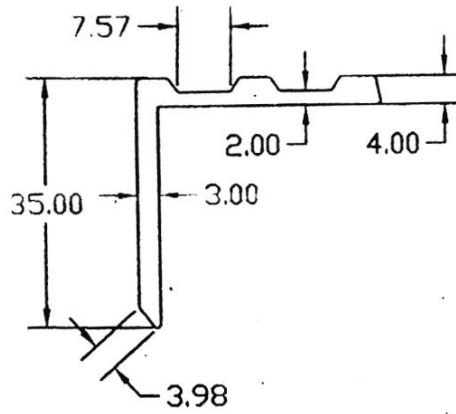

SECTION NO.	T	WEIGHT-RANGE KG/12'
2116		1.880 - 2.000

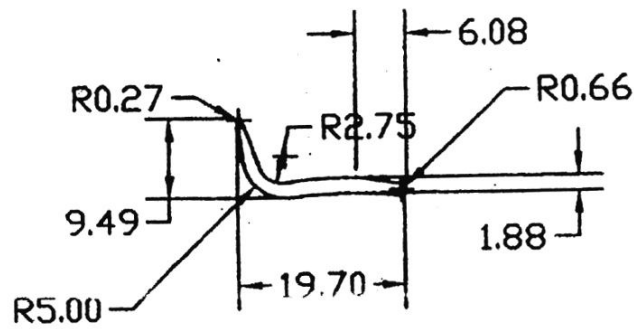

SECTION NO.	T	WEIGHT-RANGE KG/12'
2117	1.800	0.400 - 0.550

SHIV SHAKTI ALUMINIUM EXTRUSION (P) LTD.



An ISO 9001 : 2008 Certified Company

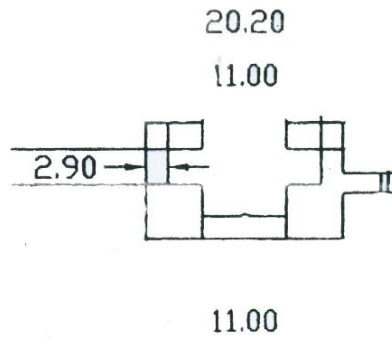

SECTION NO.	T	WEIGHT-RANGE KG/12
2118	2.900	2.100 - 2.250

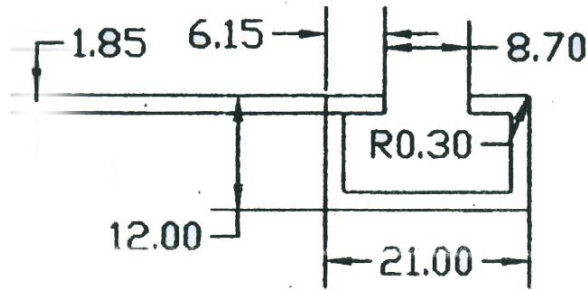

SECTION NO.	T	WEIGHT-RANGE KG/12
2119	1.85	0.900-1.150

SHIV SHAKTI ALUMINIUM EXTRUSION (P) LTD.





An ISO 9001 : 2008 Certified Company

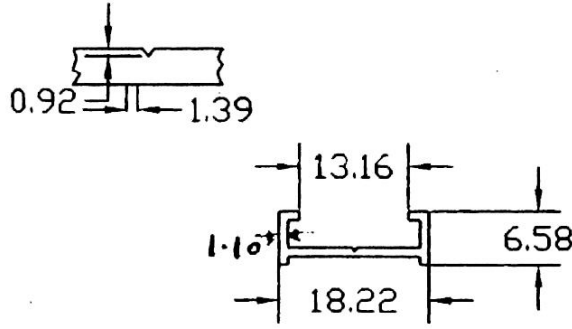

SECTION NO.	T	WEIGHT-RANGE KG/12'
2120	1.10	0.334 - 0.400

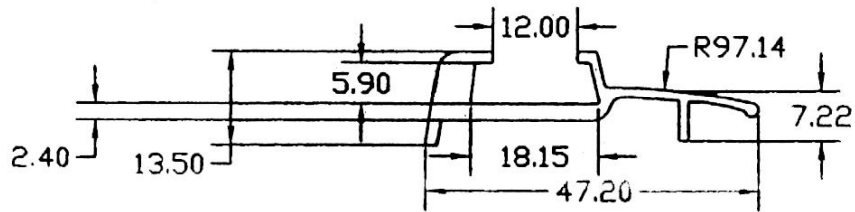

SECTION NO.	T	WEIGHT-RANGE KG/12'
2121	2.4	1.550 - 1.750

SHIV SHAKTI ALUMINIUM EXTRUSION (P) LTD.



An ISO 9001 : 2008 Certified Company



SHIV SHAKTI ALUMINIUM EXTRUSION (P) LTD.

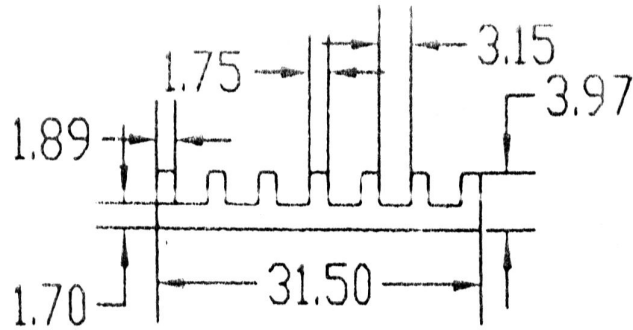

SECTION NO.	T	WEIGHT-RANGE KG/12'
2122	1.75	0.8000- 1.000

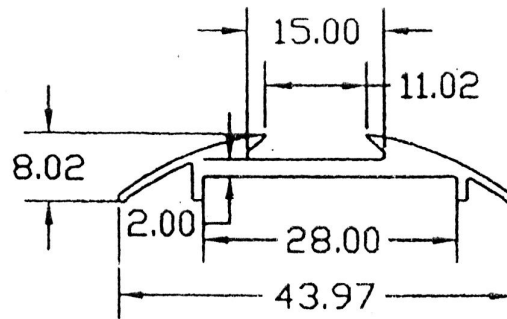

SECTION NO.	T	WEIGHT-RANGE KG/12'
2123	2.MM	1.074 - 1.250



An ISO 9001 : 2008 Certified Company

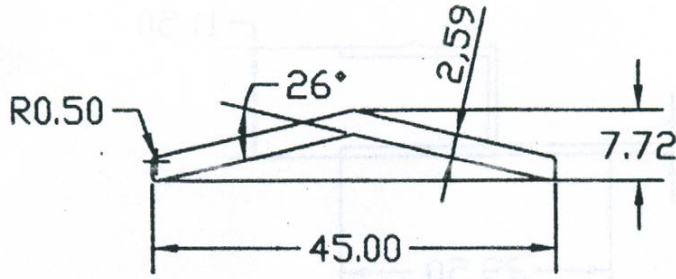

SECTION NO.	T	WEIGHT-RANGE KG/12'
2124	2.59	1.170 - 1.350

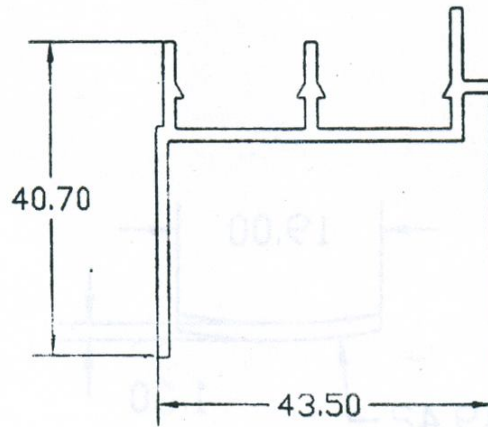

SECTION NO.	T	WEIGHT-RANGE KG/12'
2125	1.60	1.800 - 1.950

SHIV SHAKTI ALUMINIUM EXTRUSION (P) LTD.



An ISO 9001 : 2008 Certified Company

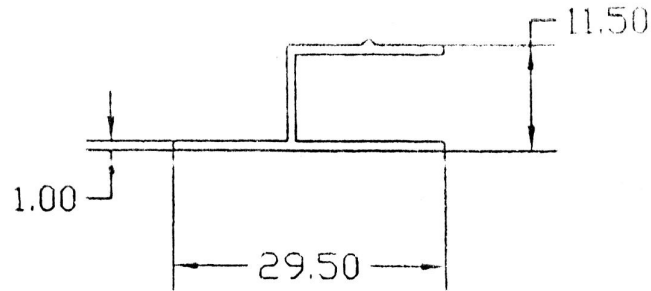

SECTION NO.	T	WEIGHT-RANGE KG/12'
2126	1.50	0.750 - 0.800

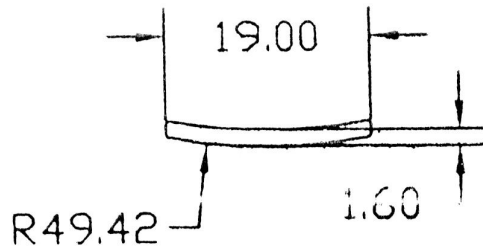

SECTION NO.	T	WEIGHT-RANGE KG/12'
2127	1.60	0.300 - 0.350

SHIV SHAKTI ALUMINIUM EXTRUSION (P) LTD.



An ISO 9001 : 2008 Certified Company



SHIV SHAKTI ALUMINIUM EXTRUSION (P) LTD.

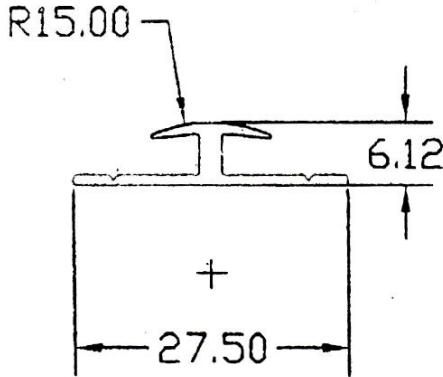

SECTION NO.	T	WEIGHT-RANGE KG/12'
2128	1.00	0.450 - 0.500

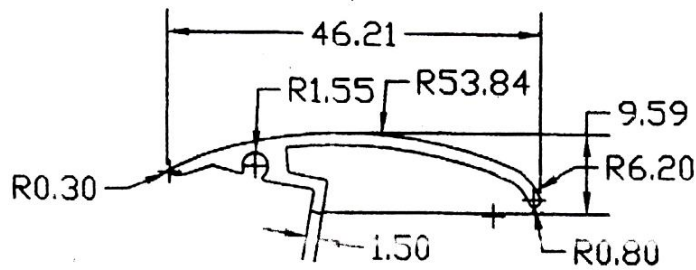

SECTION NO.	T	WEIGHT-RANGE KG/12'
2129	1.50	0.960 - 1.150



An ISO 9001 : 2008 Certified Company

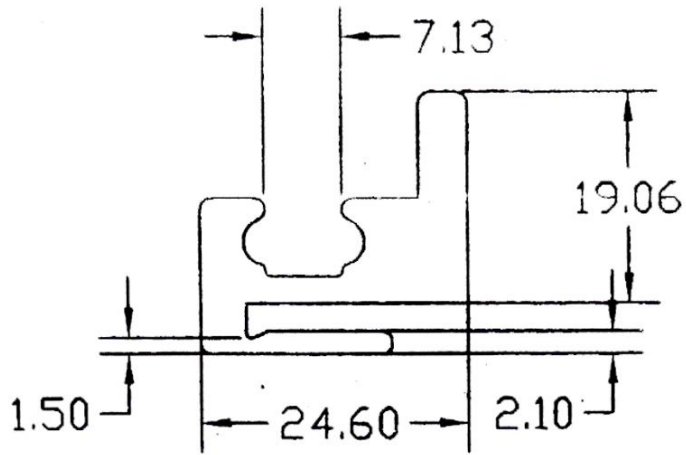

SECTION NO.	T	WEIGHT-RANGE KG/12'
2130	2.10	2.550 - 2:650

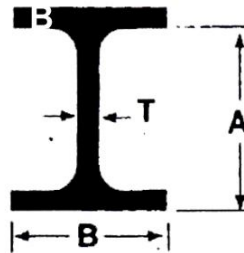

SECTION	A	B	R	T	WEIGHT - RANGE KG-12
2133	53.50	64.00	3.18	4.10	5.000
2134	82.50	60.00	3.18	6.00	12.000

SHIV SHAKTI ALUMINIUM EXTRUSION (P) LTD.