

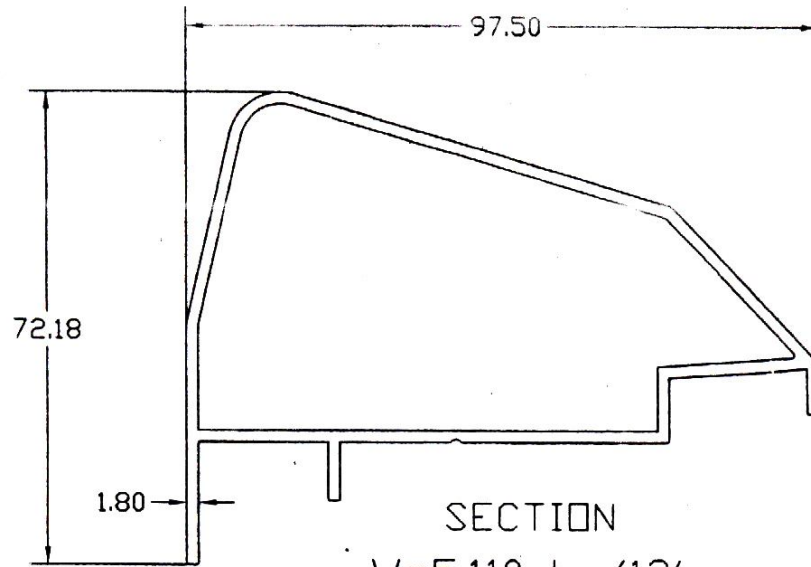

An ISO 9001 : 2008 Certified Company



SECTION  
W=5.110 kg/12'

SECTION NO.	T	WEIGHT--RANGE KG/12'
2202	1.80	5.150 - 5.350

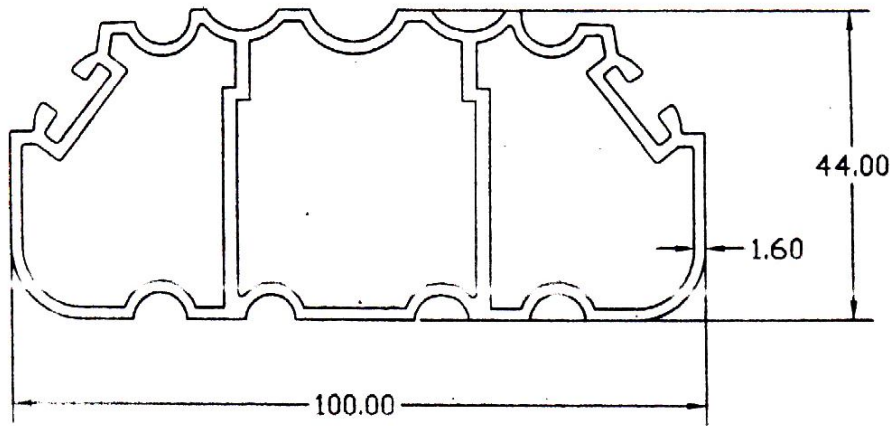

SECTION NO.	T	WEIGHT--RANGE KG/12'
2202	1.60	53100 - 5.350

SHIV SHAKTI ALUMINIUM EXTRUSION (P) LTD.



An ISO 9001 : 2008 Certified Company

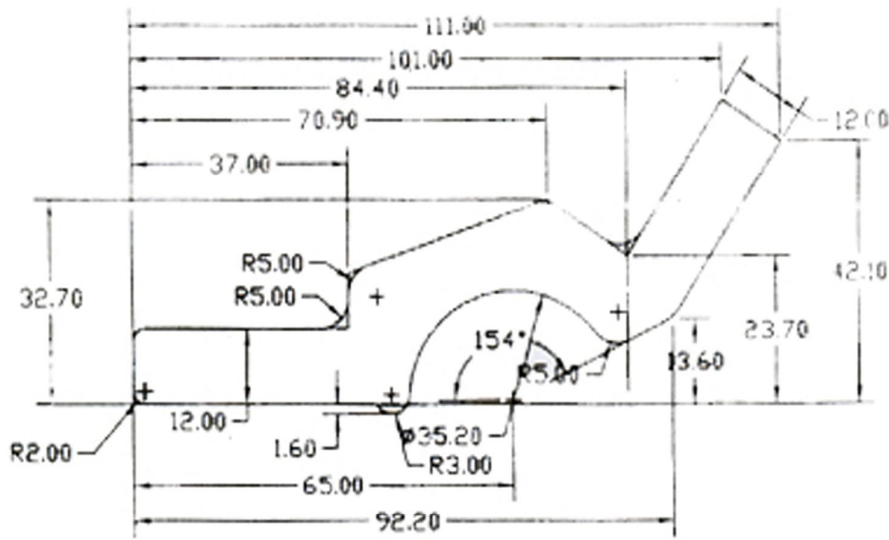

SECTION NO	T	WEIGHT-RANGE KG/12'
2203	12	16.100 - 16.350

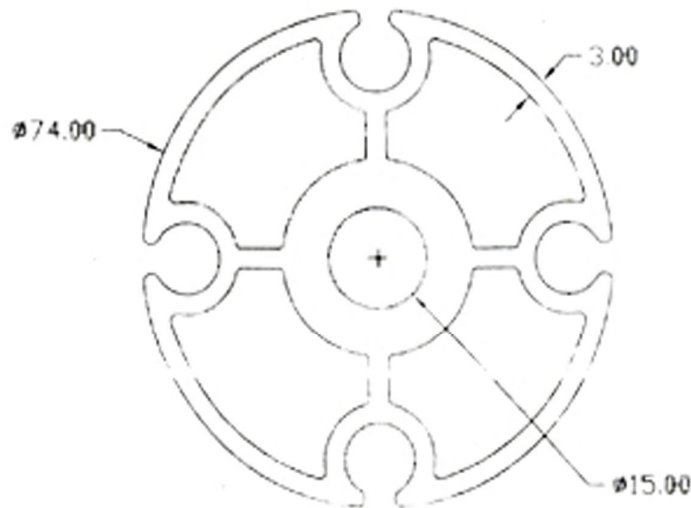

SECTION NO	T	WEIGHT-RANGE KG/12'
2204	3.00	15.650 -

SHIV SHAKTI ALUMINIUM EXTRUSION (P) LTD.



An ISO 9001 : 2008 Certified Company

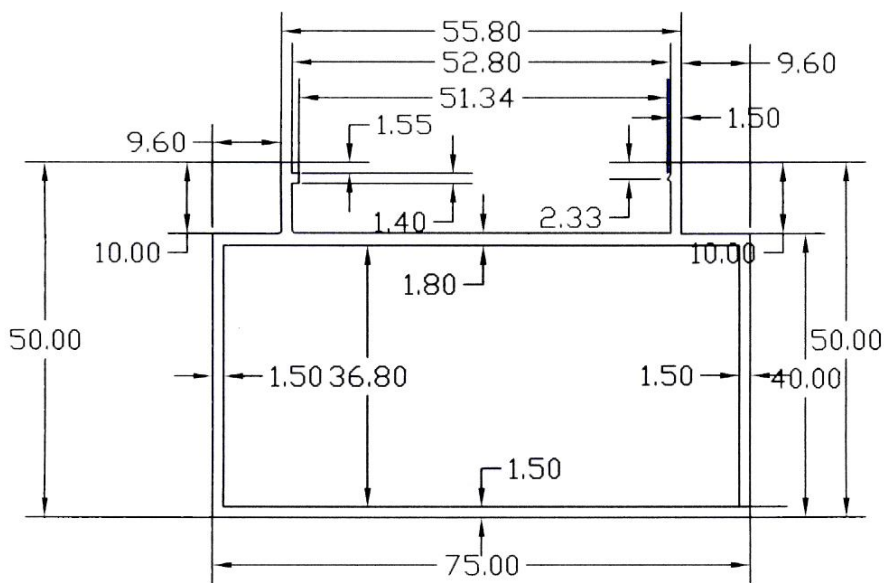

Profile-I

SECTION -NO	T	WEIGHT-RANGE KG/12'
2205	0.70	2.200

SHIV SHAKTI ALUMINIUM EXTRUSION (P) LTD.



An ISO 9001 : 2008 Certified Company

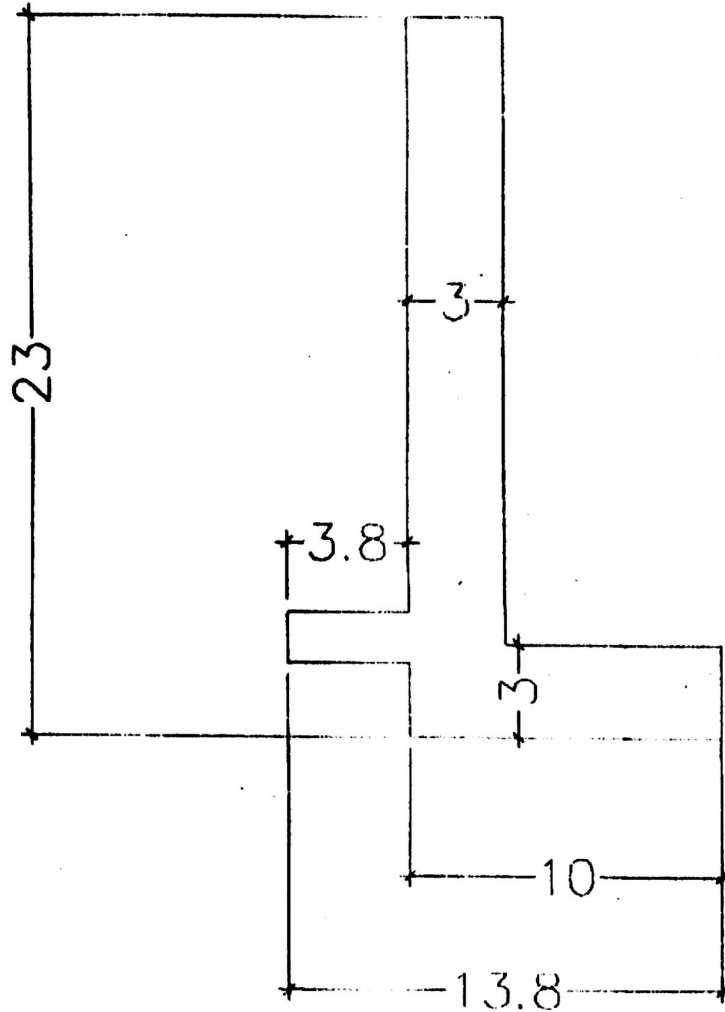

Profile-2

2206

Weight .945K1 12'

**ALUMINIUM BRACKET = 96MM<sup>2</sup>**

SHIV SHAKTI ALUMINIUM EXTRUSION (P) LTD.



An ISO 9001 : 2008 Certified Company

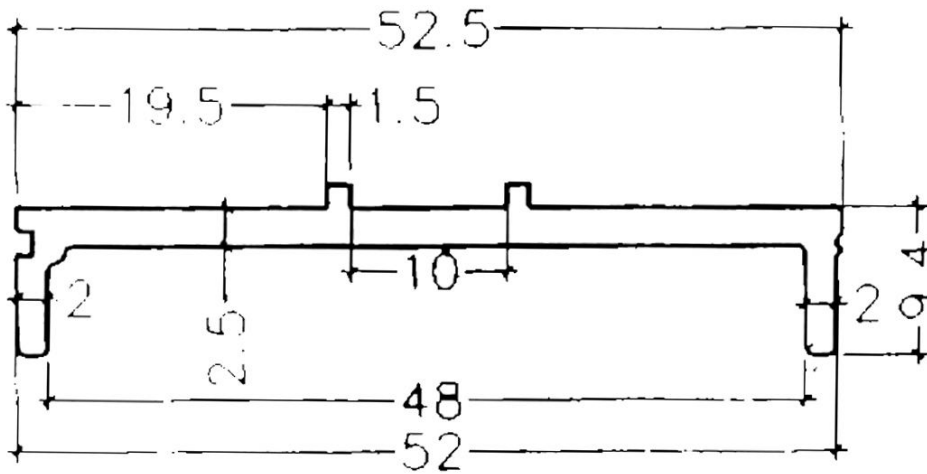

**Profile - 3  
2207**

**Wight 1-600 12'**

**PRESSURE PLATE = 164 mm<sup>2</sup>**

**SHIV SHAKTI ALUMINIUM EXTRUSION (P) LTD.**



An ISO 9001 : 2008 Certified Company

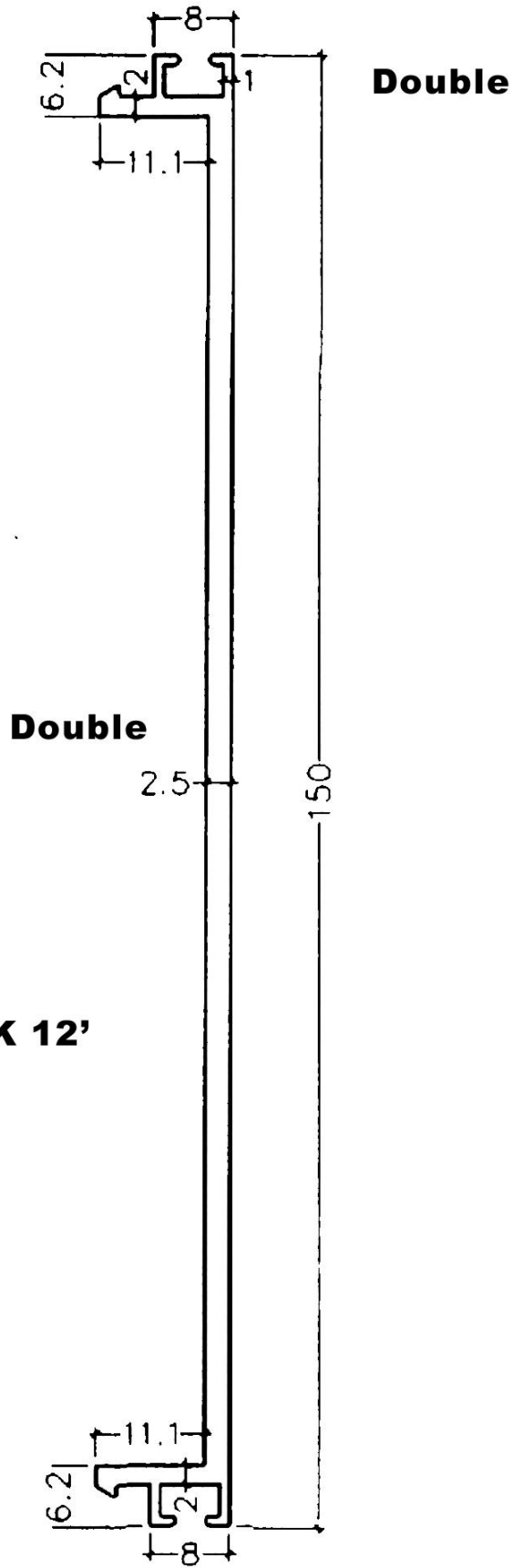

Wight 4-160K 12'

Profile - 4

2208

Wight 4-160K 12'

SHIV SHAKTI ALUMINIUM EXTRUSION (P) LTD.



An ISO 9001 : 2008 Certified Company

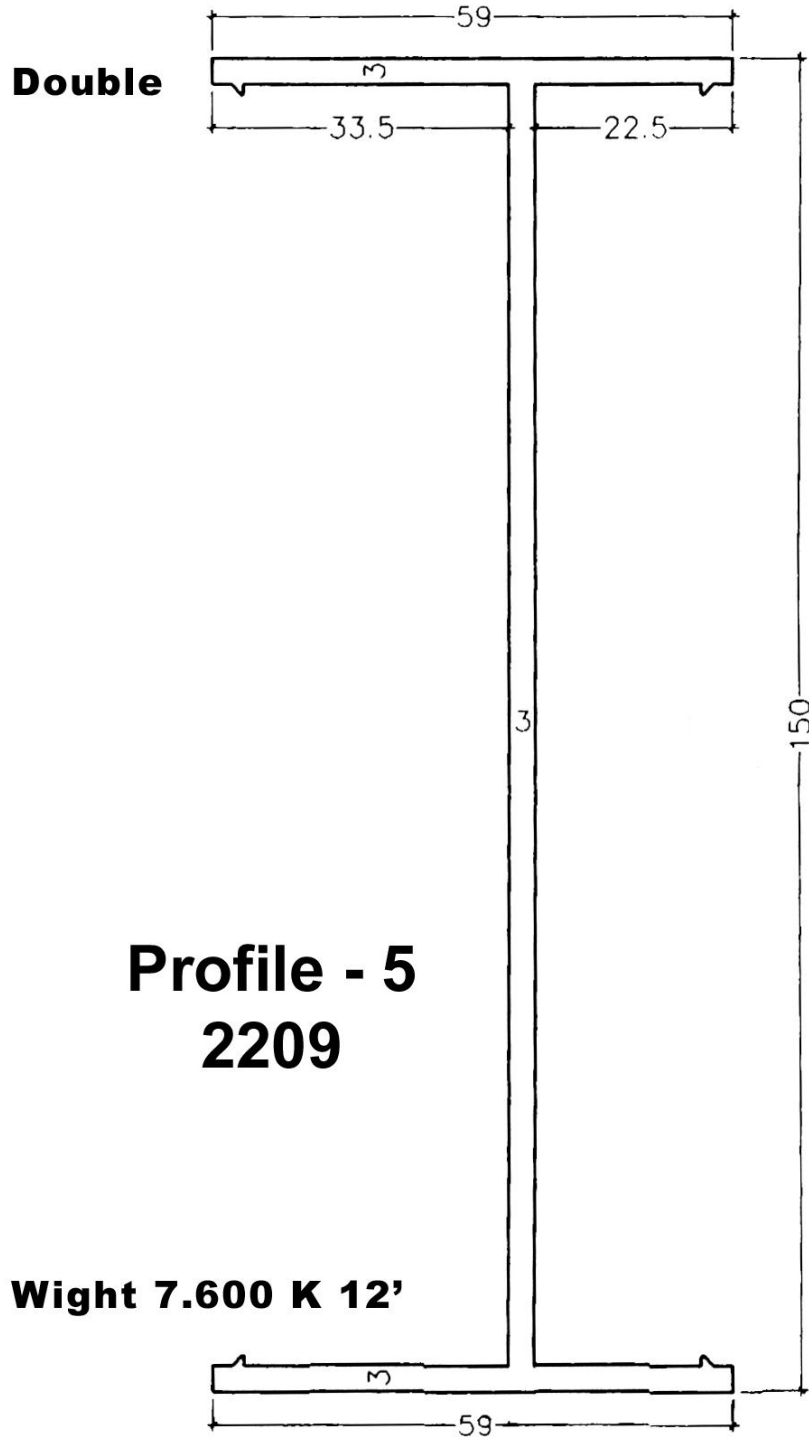

SHIV SHAKTI ALUMINIUM EXTRUSION (P) LTD.

---

**SHAE ALUMINIUM PROFILE =790 mm<sup>2</sup>**

---



An ISO 9001 : 2008 Certified Company



**Double**

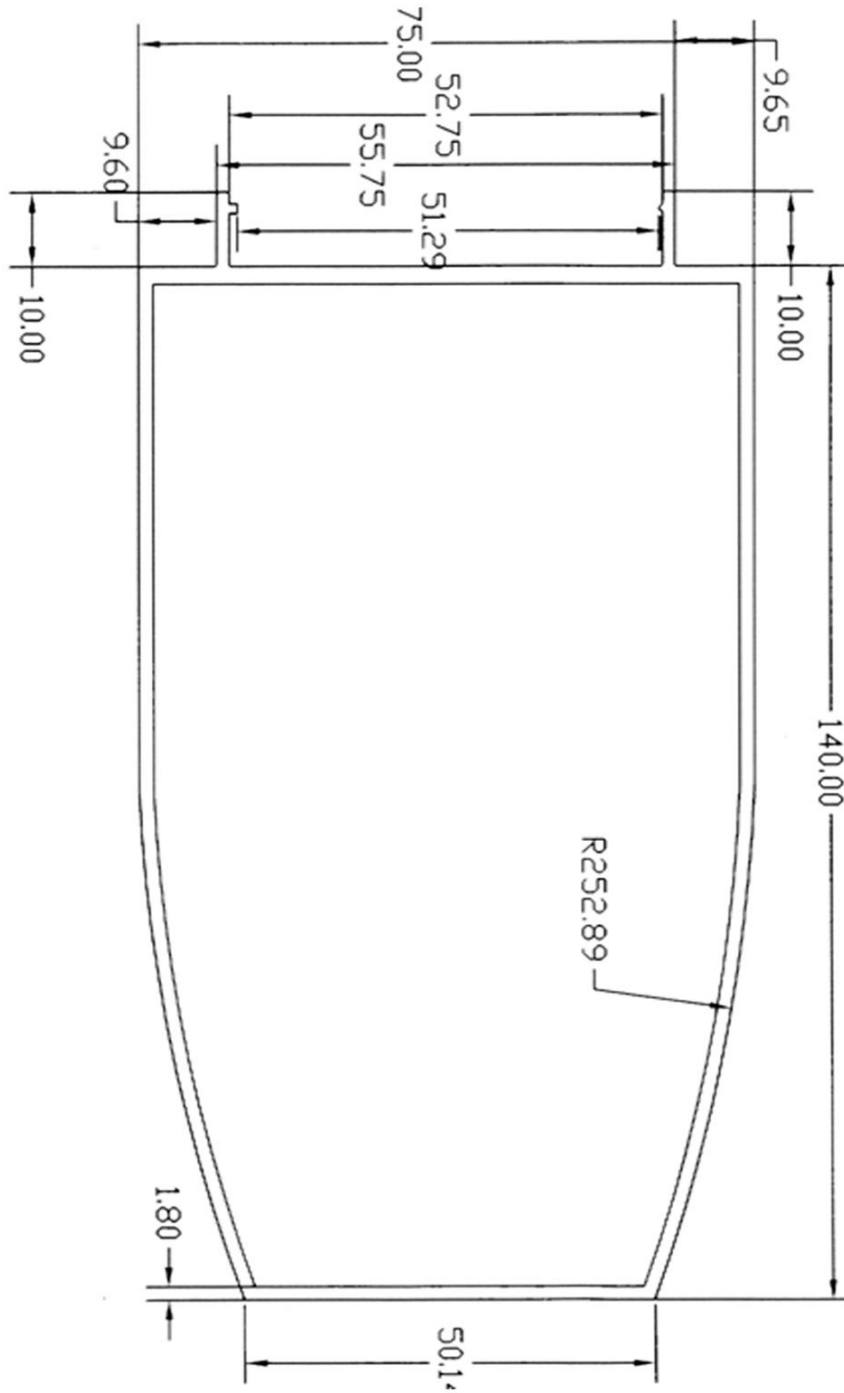

SECTION NO.	T	WEIGHT-RANGE KG/12'
2240	1.80	7.950

**SHIV SHAKTI ALUMINIUM EXTRUSION (P) LTD.**





An ISO 9001 : 2008 Certified Company



SHIV SHAKTI ALUMINIUM EXTRUSION (P) LTD.

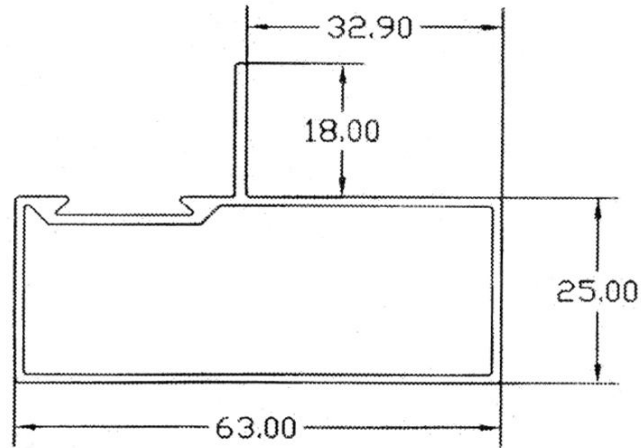

SECTION NO.	T	WEIGHT-RANGE KG/12'
2301	1.20	0.666

Mullion

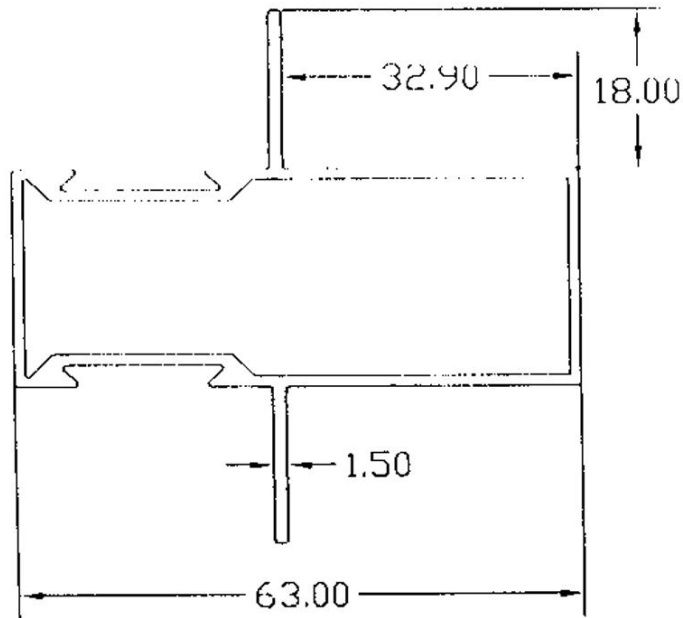

SECTION NO.	T	WEIGHT-RANGE KG/12'
2302	1.50	0.775



An ISO 9001 : 2008 Certified Company

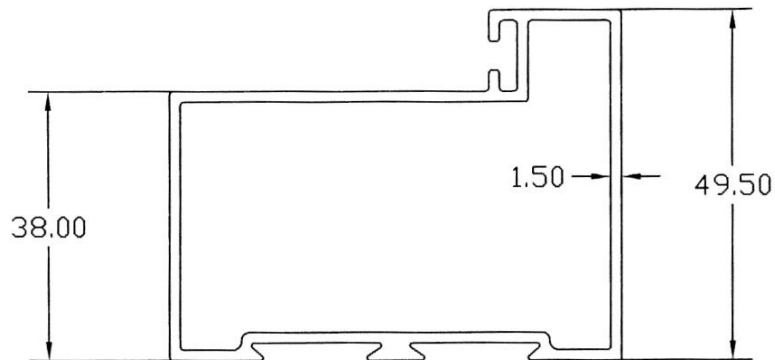

SECTION NO.	T	WEIGHT-RANGE KG/12'
2303	1.50	1.004

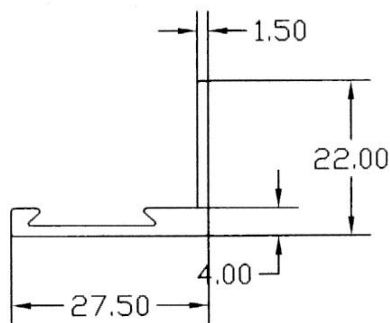

SECTION NO.	T	WEIGHT-RANGE KG/12'
2304	1.50	0.260

SHIV SHAKTI ALUMINIUM EXTRUSION (P) LTD.

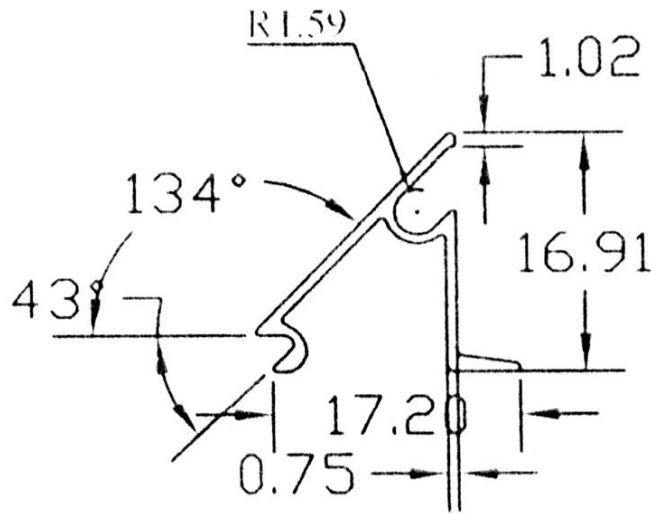

SECTION NO.	T	WEIGHT-RANGE KG/12'
2305	0.75	0.100

**Hitsink**

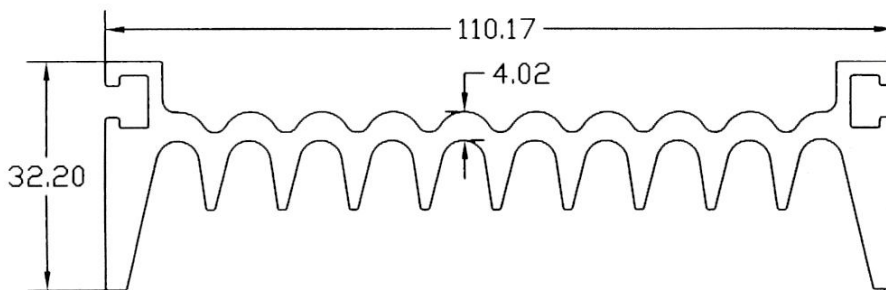

SECTION NO.	T	WEIGHT-RANGE KG/12'
2401	4.00	8,750



An ISO 9001 : 2008 Certified Company

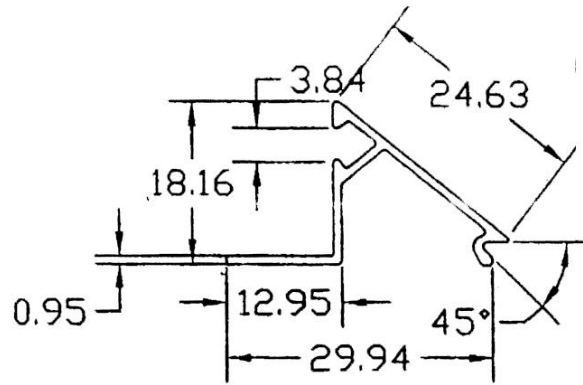

SECTION NO.	T	WEIGHT-RANGE KG/12'
2321	0.950	0.580 - 0.650

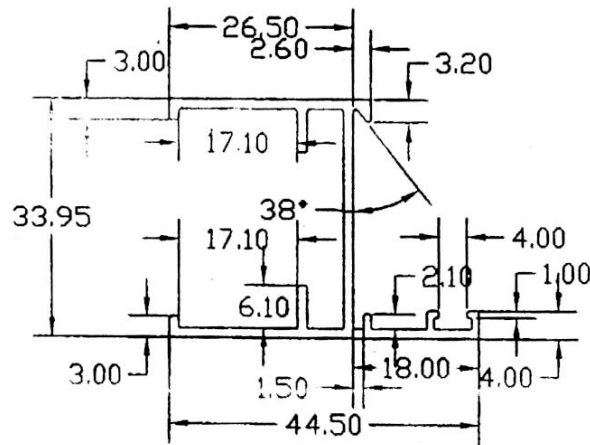

SECTION NO.	T	WEIGHT-RANGE KG/12'
2325	1.40	1.760 - 1.860

SHIV SHAKTI ALUMINIUM EXTRUSION (P) LTD.



An ISO 9001 : 2008 Certified Company

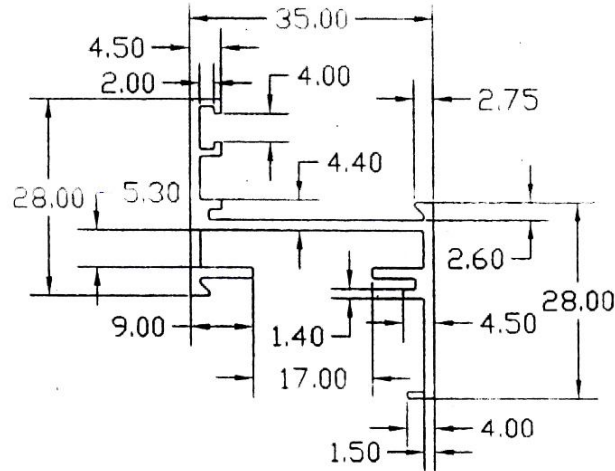

SECTION NO.	T	WEIGHT-RANGE KG/12'
2331	1.50	1.760 - 1.860

**Mullion**

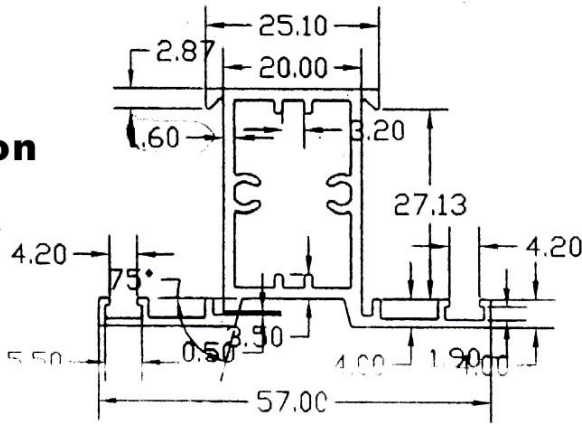

SECTION NO.	T	WEIGHT-RANGE KG/12'
2336	1.60	2.640 - 2.740

SHIV SHAKTI ALUMINIUM EXTRUSION (P) LTD.



An ISO 9001 : 2008 Certified Company



SHIV SHAKTI ALUMINIUM EXTRUSION (P) LTD.

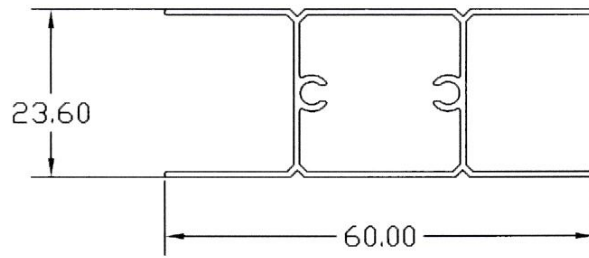

SECTION NO.	T	WEIGHT-RANGE KG/12'
2341	0.80	1.500

**Sintex 'A' Plain**

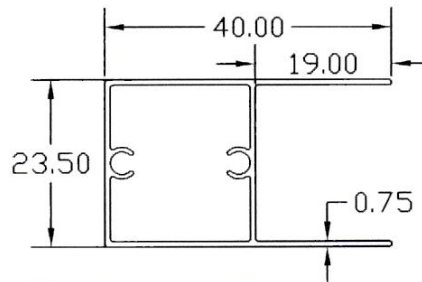

SECTION NO.	T	WEIGHT-RANGE KG/12'
2346	0.75	1.100



International Standards  
Certifications  
Lic. No. QAC/R91/1753

# AN ISO 9001 : 2008 Certified Company

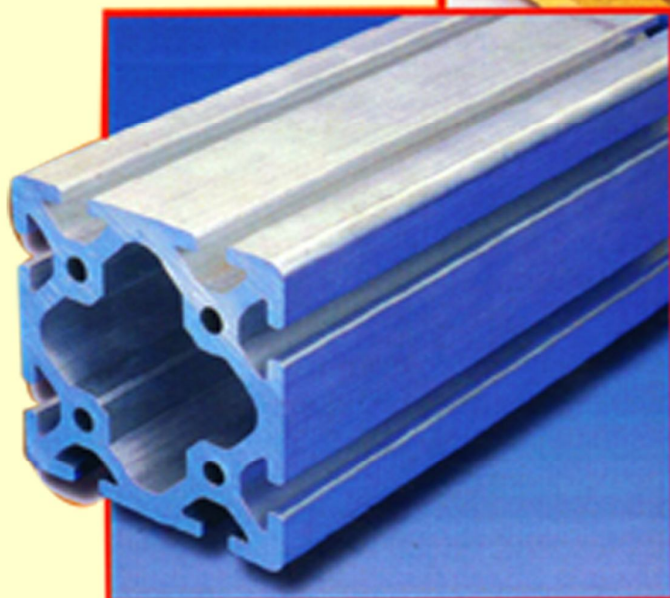

**CERTIFICATE OF REGISTRATION**



**QUALITY ASSURED COMPANY**

**ISO 9001 : 2008**  
THIS IS TO CERTIFY THAT THE  
QUALITY MANAGEMENT SYSTEM OF  
**Shiv Shakti Aluminium Extrusion Pvt. Ltd.**  
M-4 (P), 3rd Phase, Adityapur Industrial Area,  
Adityapur, Jamshedpur  
Jharkhand INDIA

Has been assessed and registered as complying with the requirements of the International Standard shown above for the following Goods and Services. Further clarifications regarding the scope of this certificate and the applicability of ISO 9001 : 2000 requirements may be obtained by consulting the organization.  
Manufacture of Extruded Aluminium Products as per customer requirements excluding Design and Development

<i>Ash Jais</i>	Registration Number:	QAC/R91/1753
Tony Wilde	Registration Date:	06/Jul/2009
Managing Director	Expiry Date:	13/Nov/2010
ISC Pty Ltd, a/b/n 31 245 60 954	Serial Number	QAC01322
Sydney, Australia		





**M-4 ( P ), 3RD PHASE, ADITYAPUR INDUSTRIAL AREA  
ADITYAPUR, JAMSHEDPUR- 831012.  
PH :- 0657-3208052, 3200137,  
FAX :- 0657- 2373474  
EMAIL :- SHIVSHAKTIALUMINIUM@REDIFFMAIL.COM**